





Empty enclosures in accordance with IEC 62208

- for customized solutions and individual applications
- for example for low-voltage switchgear and controlgear assemblies in accordance with the IEC 61439-series
- degree of protection IP 55-IP 65
- made from thermoplastics
- protection class II, 

General information	376 - 377
Empty enclosures type KG, cable entry via metric knockouts	378 - 382
Empty enclosures type K, box walls without knockouts, can be drilled individually	383 - 386
Accessories	387 - 392
Technical details	393 - 397

Further technical information can be found on the Internet
www.hensel-electric.de -> Products

IEC 62208

Enclosures for low-voltage switchgear and controlgear assemblies.
General requirements

General information

The IEC 62208 standard applies to empty enclosures, prior to the incorporation of switchgear and controlgear components by the user, as supplied by the enclosure manufacturer.

It specifies general definitions, classifications, characteristics and test requirements of enclosures to be used as part of switchgear and controlgear assemblies (e.g. in accordance with the IEC 61439-series).

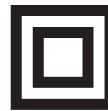

Protection against electric shock

In order to protect individuals in the event of faults against electric shock and the accompanying risks, enclosures are classified with protection class I (electrical earth) and protection class II (protection by total or reinforced insulation) according to IEC 61439, section 8.4.4. HENSEL empty enclosures are manufactured from insulating material and provide protection against electric shock according to protection class II.

IP-Codes for protecting electrical equipment against dust and water

Electrical equipment must be protected from external influences and conditions for safety reasons. The two-digit IP-Codes indicate to what extent the enclosure provides protection against hazardous parts and ingress of dust (1st digit) or water (2nd digit). For example IP 65: Electrical equipment inside the enclosure is protected against dust and harmful water and humidity.

Therefore the IP-Codes indicate the suitability of enclosures for different environmental conditions.

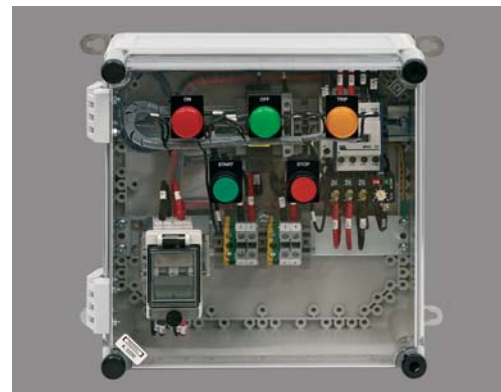

Effects on the degree of protection (IP-Code) when devices are built in the lid

If any switches, displays, push buttons or other equipment are built into the lid of an enclosure, the manufacturer must consider the effects on the degree of protection at that specific point.

The installation of electrical equipment into the lid, door or wall of an enclosure can reduce the degree of protection of the enclosure in that specific installation area depending on the degree of protection of the equipment and depending on additional measures for sealing the point of entry.

Example: The installation of an IP 44 socket into the lid of an IP 65 enclosure reduces the degree of protection in that specific area to IP 44. The enclosure itself still provides IP 65, but the manufacturer has to draw attention to the fact, that the socket only provides IP 44 for the area where it is installed.

Operating and ambient conditions

Empty enclosures according to IEC 62208 are applicable in ambient temperatures from -25 °C to +40 °C (outdoor installation) or from -5 °C to +40 °C (indoor installation).

The IEC 62208 requires the specification of the power dissipation capability P_{de} of the enclosures

Temperature rise in enclosures and power dissipation

In relationship with the outside temperatures the temperature rise inside of enclosures, caused by the flowing current and the power loss P_D of the installed electrical equipment, has to be considered.

Most devices are designed for maximum ambient temperatures of +40 °C to +55 °C. Accordingly there may only be a narrow range for the temperature rise inside of the enclosure if the ambient temperature is close to the maximum operating temperature of the installed equipment.

The enclosure with its power dissipation capability P_{de} has to be able to dissipate the power loss P_D of the installed electrical equipment inside of the enclosure without exceeding the limits of operating and ambient temperatures.

This ensures that the inside of an enclosure is not heated inadmissibly at a defined installed power loss and guarantees the operative readiness and reliable performance of the built-in electrical equipment.

The power dissipation P_D of the electrical equipment is given in the technical data of the respective manufacturers. The power dissipation capability P_{de} of Hensel empty enclosures are given in the technical data of this catalogue.

A possible application for the power dissipation capability is the verification of temperature rise in accordance with IEC 61439-1, section 10.10.

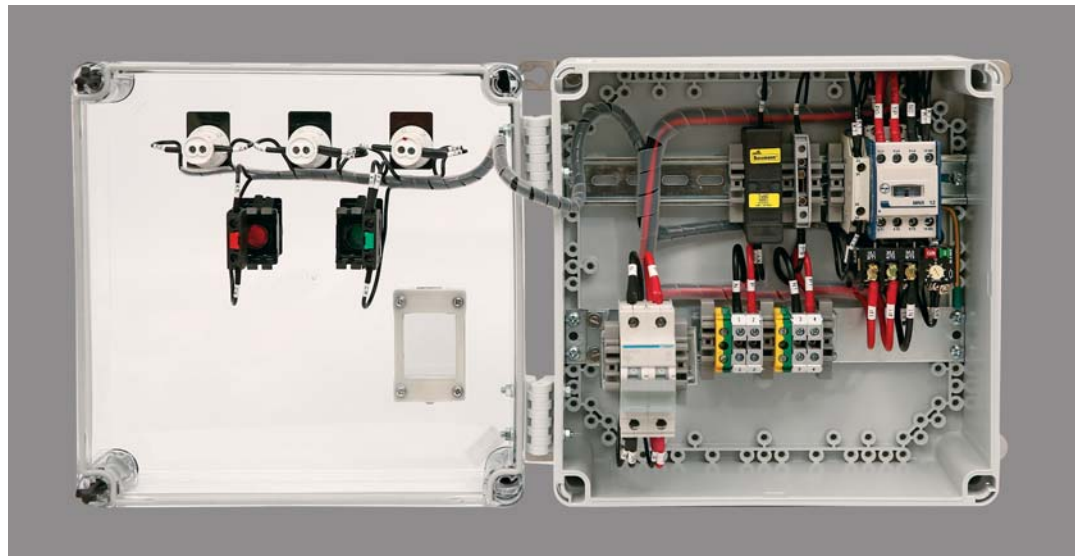

The temperature inside of enclosures rises by the flowing current and the power loss of the installed electrical equipment.

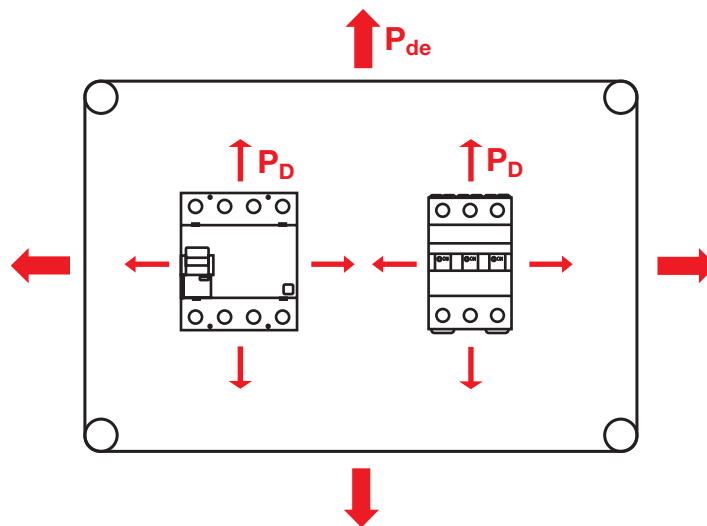

The enclosure with its power dissipation capability P_{de} has to be able to dissipate the power loss P_D of the installed electrical equipment inside of the enclosure without exceeding the limits of operating and ambient temperatures.

P_{de} = power dissipation capability
 P_D = power dissipation

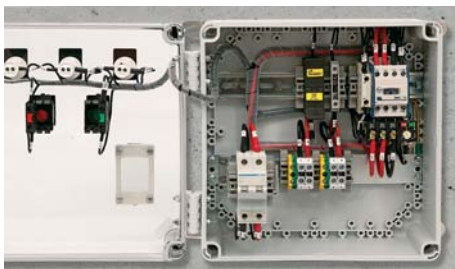
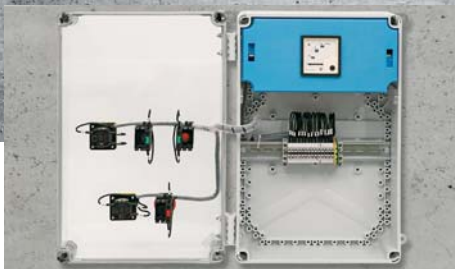
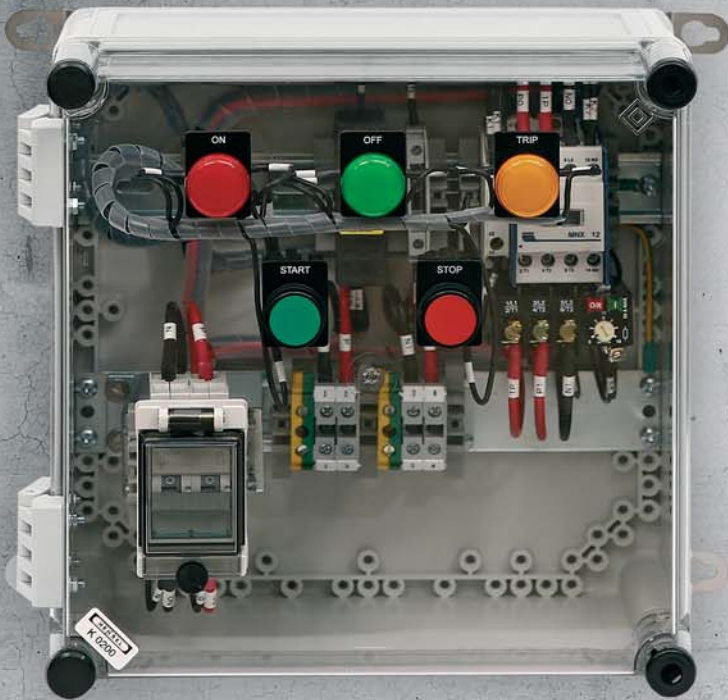

Empty enclosures in accordance with IEC 62208

**For customized solutions and individual applications
Compliance with the safety requirements of the applicable product
standard (e.g. IEC 61439-series) is the responsibility of the assembly
manufacturer and not of the enclosure manufacturer.**

- For example for low-voltage switchgear and controlgear assemblies in accordance with IEC 61439-series
- For the installation of devices that must be operated externally, such as plug devices, push buttons and switches
- Installation of electrical equipment via DIN rails or mounting plates
- Cable entry via metric knockouts respectively by drilling individually using ESM grommets or AKM cable glands, see index cable entry systems
- Fasteners for tool operation as standard
- Screws made of stainless steel V2A
- Hinges for lids available for operating installation devices within a large area
- Material: PS polystyrene or PC polycarbonate
- Burning behaviour: Glow wire test in accordance with IEC 60695-2-11: 750 °C / 960 °C, flame-retardant, self-extinguishing
- Empty enclosures are equipment with protection class II,  in accordance with IEC 61439-1, section 8.4.4
- Degree of protection: IP 55, IP 65 with cable glands
- Colour: grey, RAL 7035



KG 9001

Built-in dimensions W 101 x H 205 x D 95 mm

- degree of protection: IP 55 (ESM), IP 65 (see index cable entry systems)
- for installation equipment on DIN rails or mounting plates (order separately)
- max. installation depth with built-in mounting plate 95 mm, with built-in DIN rail 89 mm
- with transparent hinged lid
- fastener for tool operation
- sealable
- cable entry via metric knockouts
- included cable entry:
 2 ESM 25, sealing range Ø 9-17 mm and
 1 ESM 32, sealing range Ø 9-23 mm

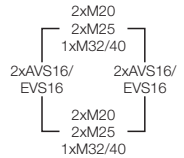
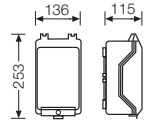

rated insulation voltage	$U_i = 1000 \text{ V a.c.}$
impact strength	IK 08 (5 Joule)
static load	mounting plate or DIN rail = 1.3 kg lid = 1.2 kg
power dissipation capability at $\Delta\theta = 40 \text{ K}$	$P_{de} = 16.5 \text{ watts}$
relative power dissipation capability in watts per K	$P_{de} = 0.4125 \text{ watts per K}$



KG 9002

Built-in dimensions W 133 x H 205 x D 95 mm

- degree of protection: IP 55 (ESM), IP 65 (see index cable entry systems)
- for installation equipment on DIN rails or mounting plates (order separately)
- max. installation depth with built-in mounting plate 95 mm, with built-in DIN rail 89 mm
- please order DIN rails or mounting plates additionally
- with transparent hinged lid
- fastener for tool operation
- sealable
- cable entry via metric knockouts
- included cable entry:
 2 ESM 25, sealing range Ø 9-17 mm and
 1 ESM 32, sealing range Ø 9-23 mm

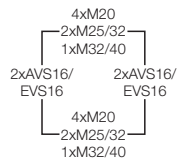
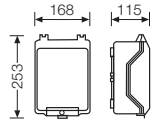

rated insulation voltage	$U_i = 1000 \text{ V a.c.}$
impact strength	IK 08 (5 Joule)
static load	mounting plate or DIN rail = 1.6 kg lid = 1.2 kg
power dissipation capability at $\Delta\theta = 40 \text{ K}$	$P_{de} = 16.8 \text{ watts}$
relative power dissipation capability in watts per K	$P_{de} = 0.42 \text{ watts per K}$

Application:



KG empty enclosures with transparent lid



KG empty enclosures with opaque lid



KG 9003

Built-in dimensions W 182 x H 205 x D 95 mm

- degree of protection: IP 55 (ESM), IP 65 (see index cable entry systems)
- for installation equipment on DIN rails or mounting plates (order separately)
- max. installation depth with built-in mounting plate 95 mm, with built-in DIN rail 89 mm
- please order DIN rails or mounting plates additionally
- with transparent hinged lid
- fastener for tool operation
- sealable
- cable entry via metric knockouts
- included cable entry:
 2 ESM 25, sealing range Ø 9-17 mm and
 1 ESM 32, sealing range Ø 9-23 mm

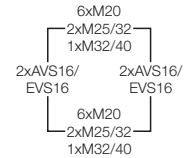
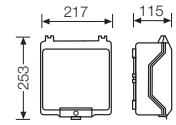

rated insulation voltage	$U_i = 1000 \text{ V a.c.}$
impact strength	IK 08 (5 Joule)
static load	mounting plate or DIN rail = 1.6 kg lid = 1.6 kg
power dissipation capability at $\Delta\theta = 40 \text{ K}$	$P_{de} = 17.6 \text{ watts}$
relative power dissipation capability in watts per K	$P_{de} = 0.44 \text{ watts per K}$

Application



Application





KG 9001 IN

Built-in dimensions W 101 x H 205 x D 95 mm

- degree of protection: IP 55 (ESM), IP 65 (see index cable entry systems)
- for installation equipment on DIN rails or mounting plates (order separately)
- max. installation depth with built-in mounting plate 95 mm, with built-in DIN rail 89 mm
- with opaque hinged lid
- fastener for tool operation
- sealable
- cable entry via metric knockouts
- included cable entry:
2 ESM 25, sealing range Ø 9-17 mm and
1 ESM 32, sealing range Ø 9-23 mm

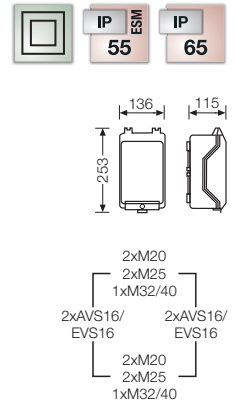

rated insulation voltage	$U_i = 1000 \text{ V a.c.}$
impact strength	IK 08 (5 Joule)
static load	mounting plate or DIN rail = 1.3 kg lid = 1.2 kg
power dissipation capability at $\Delta\theta = 40 \text{ K}$	$P_{de} = 16.5 \text{ watts}$
relative power dissipation capability in watts per K	$P_{de} = 0.4125 \text{ watts per K}$



KG 9002 IN

Built-in dimensions W 133 x H 205 x D 95 mm

- degree of protection: IP 55 (ESM), IP 65 (see index cable entry systems)
- for installation equipment on DIN rails or mounting plates (order separately)
- max. installation depth with built-in mounting plate 95 mm, with built-in DIN rail 89 mm
- with opaque hinged lid
- fastener for tool operation
- sealable
- cable entry via metric knockouts
- included cable entry:
2 ESM 25, sealing range Ø 9-17 mm and
1 ESM 32, sealing range Ø 9-23 mm

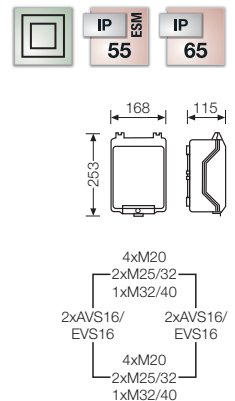

rated insulation voltage	$U_i = 1000 \text{ V a.c.}$
impact strength	IK 08 (5 Joule)
static load	mounting plate or DIN rail = 1.6 kg lid = 1.2 kg
power dissipation capability at $\Delta\theta = 40 \text{ K}$	$P_{de} = 16.8 \text{ watts}$
relative power dissipation capability in watts per K	$P_{de} = 0.42 \text{ watts per K}$

Application:



KG empty enclosures with transparent lid



KG empty enclosures with opaque lid



KG 9003 IN

Built-in dimensions W 182 x H 205 x D 95 mm

- degree of protection: IP 55 (ESM), IP 65 (see index cable entry systems)
- for installation equipment on DIN rails or mounting plates (order separately)
- max. installation depth with built-in mounting plate 95 mm, with built-in DIN rail 89 mm
- with opaque hinged lid
- fastener for tool operation
- sealable
- cable entry via metric knockouts
- included cable entry:
 2 ESM 25, sealing range Ø 9-17 mm and
 1 ESM 32, sealing range Ø 9-23 mm

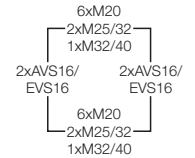
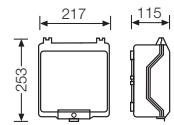

rated insulation voltage	$U_i = 1000 \text{ V a.c.}$
impact strength	IK 08 (5 Joule)
static load	mounting plate or DIN rail = 1.6 kg lid = 1.6 kg
power dissipation capability at $\Delta\theta = 40 \text{ K}$	$P_{de} = 17.6 \text{ watts}$
relative power dissipation capability in watts per K	$P_{de} = 0.44 \text{ watts per K}$

Application



Application





K 0100

Built-in dimensions W 275 x H 125 x D 150 mm

- enclosure size 1, type Mi
- for installation equipment on DIN rails or mounting plates (order separately)
- max. installation depth with built-in mounting plate 146 mm, with built-in DIN rail 135 mm
- with transparent lid
- lid fasteners for tool operation
- sealable
- box walls without knockouts
- optional hinges for device installation in the lid
- external brackets for wall fixing as accessories

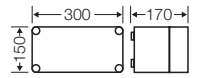

rated insulation voltage	$U_i = 690 \text{ V a.c.} / 1000 \text{ V d.c.}$
impact strength	IK 08 (5 Joule)
static load	mounting plate or DIN rail = 3.2 kg lid = 1.3 kg
power dissipation capability at $\Delta\theta = 40 \text{ K}$	$P_{de} = 33 \text{ watts}$
relative power dissipation capability in watts per K	$P_{de} = 0.825 \text{ watts per K}$



K 0101

Built-in dimensions W 275 x H 125 x D 150 mm

- enclosure size 1, type Mi
- for installation equipment on DIN rails or mounting plates (order separately)
- max. installation depth with built-in mounting plate 146 mm, with built-in DIN rail 135 mm
- with opaque lid
- lid fasteners for tool operation
- sealable
- box walls without knockouts
- optional hinges for device installation in the lid
- external brackets for wall fixing as accessories

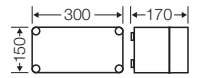

rated insulation voltage	$U_i = 690 \text{ V a.c.} / 1000 \text{ V d.c.}$
impact strength	IK 08 (5 Joule)
static load	mounting plate or DIN rail = 3.2 kg lid = 1.3 kg
power dissipation capability at $\Delta\theta = 40 \text{ K}$	$P_{de} = 33 \text{ watts}$
relative power dissipation capability in watts per K	$P_{de} = 0.825 \text{ watts per K}$

Application:



Empty enclosures with installed equipment on DIN rail and mounting plate



DIN rails for equipment or terminals with clip-on mounting



Mounting plates



K 0200

Built-in dimensions W 275 x H 275 x D 150 mm

- enclosure size 2, type Mi
- for installation equipment on DIN rails or mounting plates (order separately)
- max. installation depth with built-in mounting plate 146 mm, with built-in DIN rail 135 mm
- with transparent lid
- lid fasteners for tool operation
- sealable
- box walls without knockouts
- optional hinges for device installation in the lid
- external brackets for wall fixing as accessories

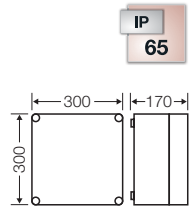

rated insulation voltage	$U_i = 690 \text{ V a.c.} / 1000 \text{ V d.c.}$
impact strength	IK 08 (5 Joule)
static load	mounting plate or DIN rail = 6.5 kg lid = 1.6 kg
power dissipation capability at $\Delta\theta = 40 \text{ K}$	$P_{de} = 53 \text{ watts}$
relative power dissipation capability in watts per K	$P_{de} = 1.325 \text{ watts per K}$



K 0201

Built-in dimensions W 275 x H 275 x D 150 mm

- enclosure size 2, type Mi
- for installation equipment on DIN rails or mounting plates (order separately)
- max. installation depth with built-in mounting plate 146 mm, with built-in DIN rail 135 mm
- with opaque lid
- lid fasteners for tool operation
- sealable
- box walls without knockouts
- optional hinges for device installation in the lid
- external brackets for wall fixing as accessories

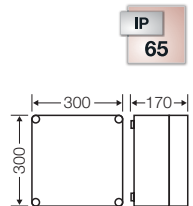

rated insulation voltage	$U_i = 690 \text{ V a.c.} / 1000 \text{ V d.c.}$
impact strength	IK 08 (5 Joule)
static load	mounting plate or DIN rail = 6.5 kg lid = 1.6 kg
power dissipation capability at $\Delta\theta = 40 \text{ K}$	$P_{de} = 53 \text{ watts}$
relative power dissipation capability in watts per K	$P_{de} = 1.325 \text{ watts per K}$

DIN rails for equipment or terminals with clip-on mounting



Mounting plates for equipment

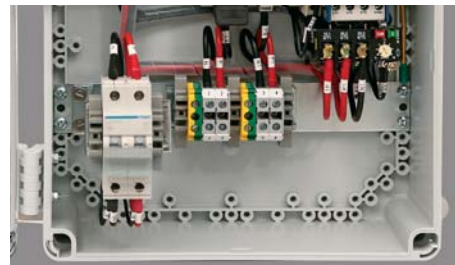

Empty enclosures in accordance with IEC 62208 for customized solutions and individual applications box walls without knockouts



K 0300

Built-in dimensions W 275 x H 425 x D 150 mm

- enclosure size 3, type Mi
- for installation equipment on DIN rails or mounting plates (order separately)
- max. installation depth with built-in mounting plate 146 mm, with built-in DIN rail 135 mm
- with transparent lid
- lid fasteners for tool operation
- sealable
- box walls without knockouts
- optional hinges for device installation in the lid
- external brackets for wall fixing as accessories

IP
65

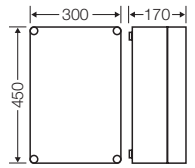

rated insulation voltage	$U_i = 690 \text{ V a.c.} / 1000 \text{ V d.c.}$
impact strength	IK 08 (5 Joule)
static load	mounting plate or DIN rail = 9.2 kg lid = 3.2 kg
power dissipation capability at $\Delta\theta = 40 \text{ K}$	$P_{de} = 71 \text{ watts}$
relative power dissipation capability in watts per K	$P_{de} = 1.775 \text{ watts per K}$



K 0301

Built-in dimensions W 275 x H 425 x D 150 mm

- enclosure size 3, type Mi
- for installation equipment on DIN rails or mounting plates (order separately)
- max. installation depth with built-in mounting plate 146 mm, with built-in DIN rail 135 mm
- with opaque lid
- lid fasteners for tool operation
- sealable
- box walls without knockouts
- optional hinges for device installation in the lid
- external brackets for wall fixing as accessories

IP
65

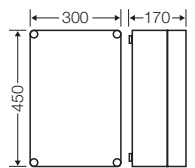

rated insulation voltage	$U_i = 690 \text{ V a.c.} / 1000 \text{ V d.c.}$
impact strength	IK 08 (5 Joule)
static load	mounting plate or DIN rail = 9.2 kg lid = 3.2 kg
power dissipation capability at $\Delta\theta = 40 \text{ K}$	$P_{de} = 71 \text{ watts}$
relative power dissipation capability in watts per K	$P_{de} = 1.775 \text{ watts per K}$

Application:



Empty enclosures with installed equipment on DIN rail and mounting plate



DIN rails for equipment or terminals with clip-on mounting



Mounting plates

Empty enclosures in accordance with IEC 62208 for customized solutions and individual applications box walls without knockouts



K 0400

Built-in dimensions W 275 x H 575 x D 150 mm

- enclosure size 4, type Mi
- for installation equipment on DIN rails or mounting plates (order separately)
- max. installation depth with built-in mounting plate 146 mm, with built-in DIN rail 135 mm
- with transparent lid
- lid fasteners for tool operation
- sealable
- box walls without knockouts
- optional hinges for device installation in the lid
- external brackets for wall fixing as accessories

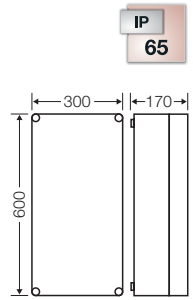

rated insulation voltage	$U_i = 690 \text{ V a.c.} / 1000 \text{ V d.c.}$
impact strength	IK 08 (5 Joule)
static load	mounting plate or DIN rail = 9.2 kg lid = 3.2 kg
power dissipation capability at $\Delta\theta = 40 \text{ K}$	$P_{de} = 93 \text{ watts}$
relative power dissipation capability in watts per K	$P_{de} = 2,325 \text{ watts per K}$



K 0401

Built-in dimensions W 275 x H 575 x D 150 mm

- enclosure size 4, type Mi
- for installation equipment on DIN rails or mounting plates (order separately)
- max. installation depth with built-in mounting plate 146 mm, with built-in DIN rail 135 mm
- with opaque lid
- lid fasteners for tool operation
- sealable
- box walls without knockouts
- optional hinges for device installation in the lid
- external brackets for wall fixing as accessories

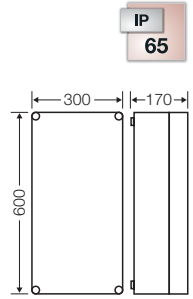

rated insulation voltage	$U_i = 690 \text{ V a.c.} / 1000 \text{ V d.c.}$
impact strength	IK 08 (5 Joule)
static load	mounting plate or DIN rail = 9.2 kg lid = 3.2 kg
power dissipation capability at $\Delta\theta = 40 \text{ K}$	$P_{de} = 93 \text{ watts}$
relative power dissipation capability in watts per K	$P_{de} = 2,325 \text{ watts per K}$

DIN rails for equipment or terminals with clip-on mounting



Mounting plates for equipment

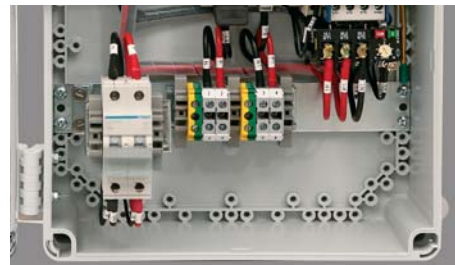

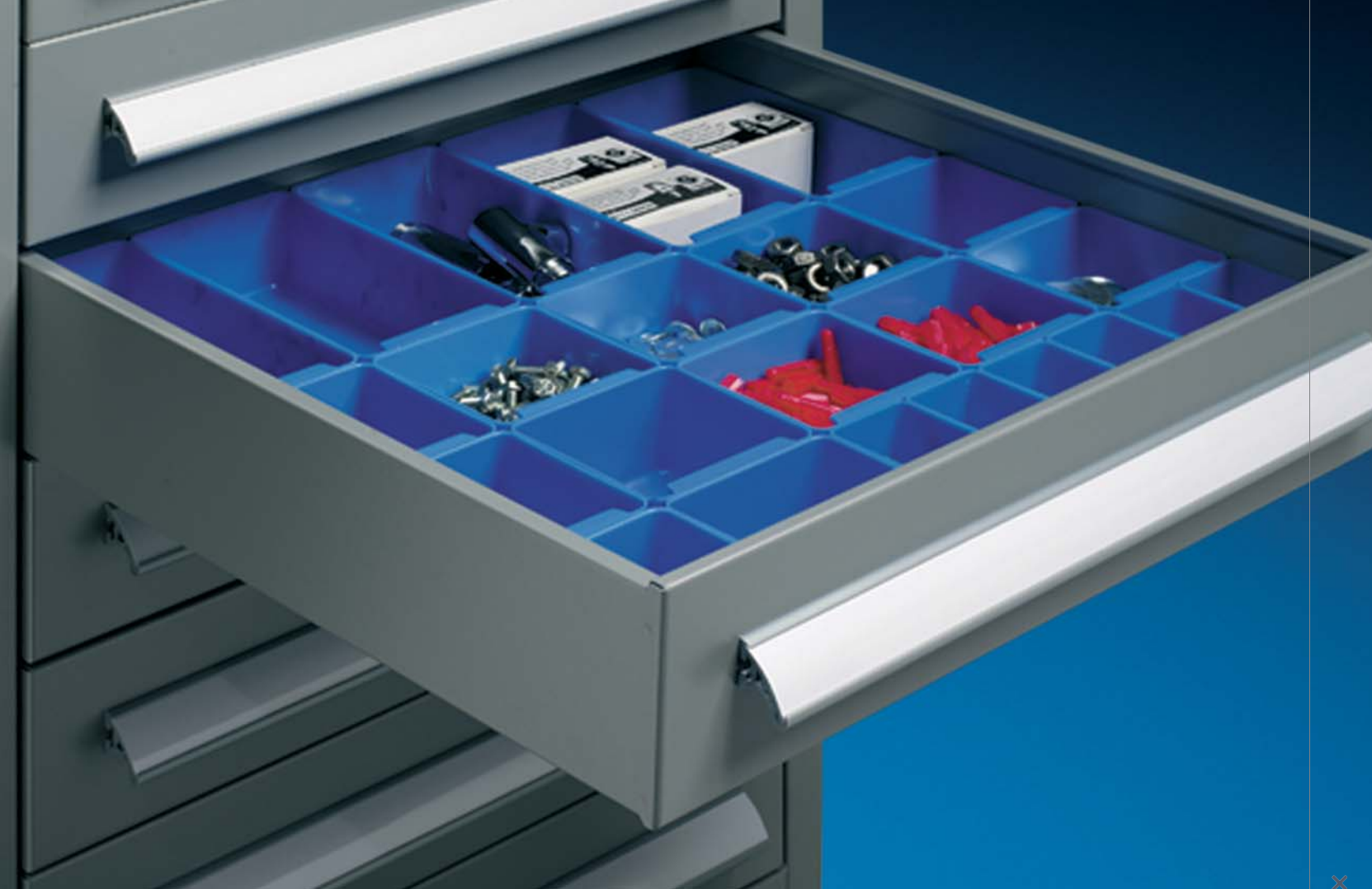

Empty enclosures in accordance with IEC 62208

Accessories

KG empty enclosures: DIN rails, mounting plates, PE/N terminals	388
K empty enclosures: DIN rails, mounting plates	389 - 390
Converting sets for lid operation or sealing	391
Locking device insertion, lid locks, triangle lid fastener, triangle key	391
Hinges for lids	392



KG MP 01

Mounting plate for KG 9001

- material laminated paper, coated
- material thickness 4 mm
- with fixing screws

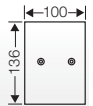

KG MP 02

Mounting plate for KG 9002

- material laminated paper, coated
- material thickness 4 mm
- with fixing screws

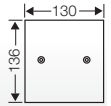

KG MP 03

Mounting plate for KG 9003

- material laminated paper, coated
- material thickness 4 mm
- with fixing screws

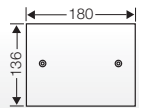

KG TS 01

DIN rail for KG 9001

- in accordance with DIN EN 60715
- for equipment or terminals with clip-on mounting
- with fixing screws

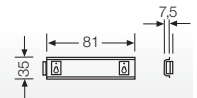

KG TS 02

DIN rail for KG 9002

- in accordance with DIN EN 60715
- for equipment or terminals with clip-on mounting
- with fixing screws

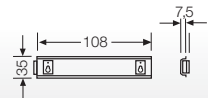

KG TS 03

DIN rail for KG 9003

- in accordance with DIN EN 60715
- for equipment or terminals with clip-on mounting
- with fixing screws

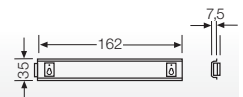

KG PN 01

PE and N terminal

- for KG 9001
- per PE/N number x cross section 3 x 25 mm², 3 x 4 mm² Cu, screw-type terminal

rated insulation voltage U_i = 400 V a.c.



KG PN 02

PE and N terminal

- for KG 9002
- PE+N x cross section 3 x 25 mm², 5 x 4 mm² Cu, screw-type terminal

rated insulation voltage U_i = 400 V a.c.



KG PN 03

PE and N terminal

- for KG 9003
- per PE/N number x cross section 4 x 25 mm², 7 x 4 mm² Cu, screw-type terminal

rated insulation voltage U_i = 400 V a.c.



Mi TS 15

DIN rail
length 134 mm

- in accordance with DIN EN 60715
- for Mi-Empty boxes sizes 1, 6
- for equipment or terminals with clip-on mounting
- with fixing screws

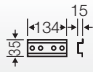

Mi TS 30

DIN rail
length 284 mm

- in accordance with DIN EN 60715
- for Mi-Empty boxes sizes 1, 2, 3, 4, 6, 8
- for equipment or terminals with clip-on mounting
- with fixing screws

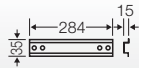

Mi TS 45

DIN rail
length 434 mm

- in accordance with DIN EN 60715
- for Mi-Empty boxes sizes 3, 6
- for equipment or terminals with clip-on mounting
- with fixing screws



Mi TS 60

DIN rail
length 584 mm

- in accordance with DIN EN 60715
- for Mi-Empty boxes sizes 4, 6, 8
- for equipment or terminals with clip-on mounting
- with fixing screws



Application:



DIN rails for equipment
or terminals with clip-on
mounting



Mi MP 1

Mounting plate
W 259 x H 115 mm

- material thickness 4 mm
- for Mi-Empty boxes sizes 1, 2, 3, 4, 6
- with fixing screws



Mi MP 2

Mounting plate
W 265 x H 265 mm

- material thickness 4 mm
- for Mi-Empty boxes sizes 2, 3, 4, 6, 8
- with fixing screws

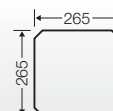

Mi MP 3

Mounting plate
W 265 x H 415 mm

- material thickness 4 mm
- for Mi-Empty boxes sizes 3, 4, 6
- with fixing screws

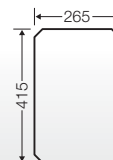

Mi MP 4

Mounting plate
W 265 x H 565 mm

- material thickness 4 mm
- for Mi-Empty boxes sizes 4, 6, 8
- with fixing screws

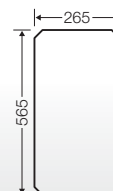

Application:



Mounting plates



Mi PL 2

Sealing cap

- 2 sealing caps for converting the lid fasteners



Mi SR 4

**Conversion set
for manual operation on tool operation**

- 4 fastening covers



Mi SN 4

**Conversion set
for converting lid fasteners from tool to manual operation**

- 4 manual actuators



Mi DV 01

Locking device insertion

- only in connection with Mi PL 2, Mi SR 4 or Mi SN 4



Mi ZS 11

**Lid lock
with locking device I
for Mi boxes sizes 1 to 6**

- Is being used instead of fasteners for hand or tool operation in order to prevent unauthorised opening of the lids
- consisting of: cylinder lock, keys, locking device insertion, dust cover



Mi ZS 12

**Lid lock
with locking device II
for Mi boxes sizes 1 to 6**

- Is being used instead of fasteners for hand or tool operation in order to prevent unauthorised opening of the lids
- consisting of: cylinder lock, keys, locking device insertion, dust cover



Mi DR 04

**Lid fastener for tool operation
triangle 8 mm**

- is used instead of fasteners for hand- or tool operation, in order to make unauthorized opening of lids more difficult
- 4 locking devices with triangle 8 mm and key



DS 1

Triangular key 8 mm



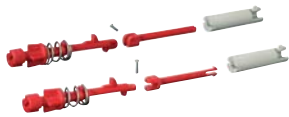

Mi ZS 20
Mi hinge for lids
for Mi boxes sizes 1, 2, 3, 4

- For operating installation device within a large area. The lid keeps permanently connected to the box.
- When assembling several boxes, the insertion can only be carried out for the external boxes.



Mi ZS 30
Hinge for lids

- for empty boxes K 0xxx
- with lamellar plugs for 2 lid fixing tubes
- The lid keeps permanently connected to the box



Mi ZS 40
Mi hinge for lids
for Mi boxes sizes 1 to 8

- For operating installation device within a large area. The lid keeps permanently connected to the box.
- Wall connectors or flanges are necessary for assembly
- Not applicable in boxes with covers



Mi ZS 60
Mi hinge for lids
for Mi boxes sizes 4 and 8 with extension frame

- For operating installation device within a large area. The lid keeps permanently connected to the box.
- Wall connectors or flanges are necessary for assembly
- Not applicable in boxes with covers



Mi ZR 4
Extension frame
for enclosure size 4

- for extension of the installation depth by 85 mm
- degree of protection IP 65 is maintained with use of up to two extension frames
- inclusive fixing material

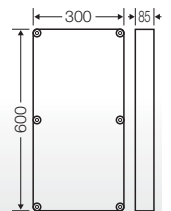

Application:



Mi hinges for lids enable to operate installation devices within a large area



Empty enclosures in accordance with IEC 62208

Technical details

Dimensions in mm	394 - 395
Power dissipation	396
Operating and ambient conditions	397

Technical details
Dimensions in mm

Dimensions of the interior installation depth with installed mounting plates.

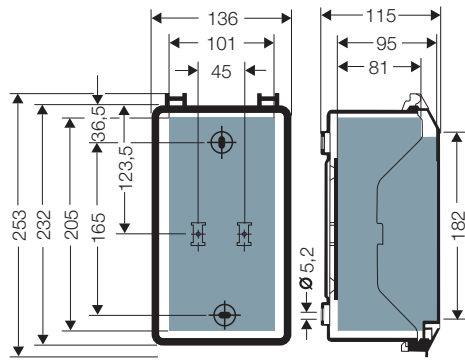

KG 9001
KG 9001 IN

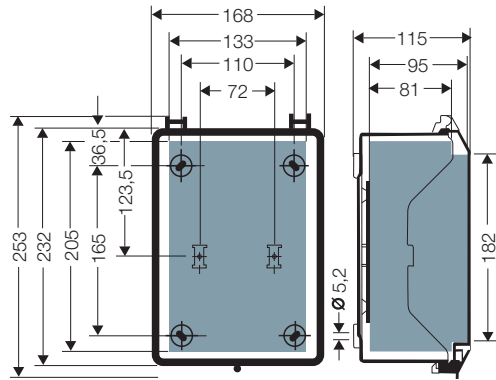

KG 9002
KG 9002 IN

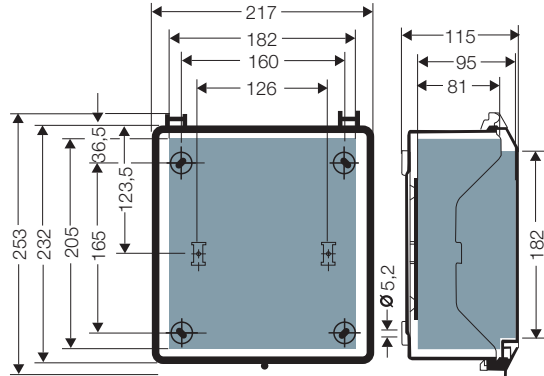

KG 9003
KG 9003 IN

 = usable installation space with mounted cable glands

Technical details
Dimensions in mm

Dimensions of the interior installation depth with installed mounting plates.

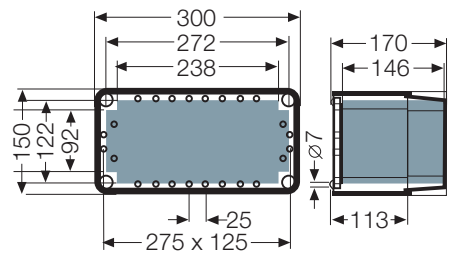

K 0100
K 0101

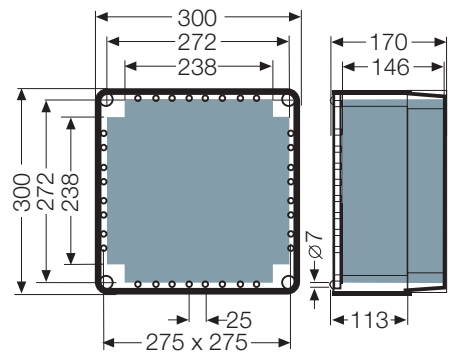

K 0200
K 0201

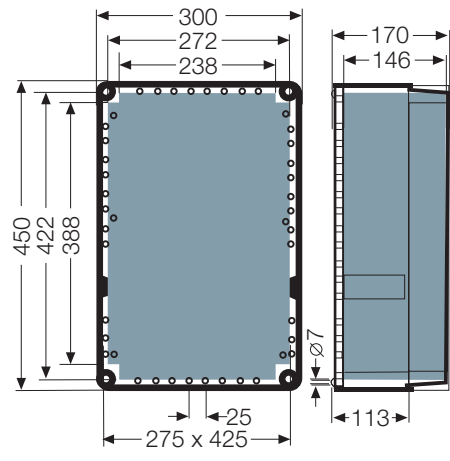

K 0300
K 0301

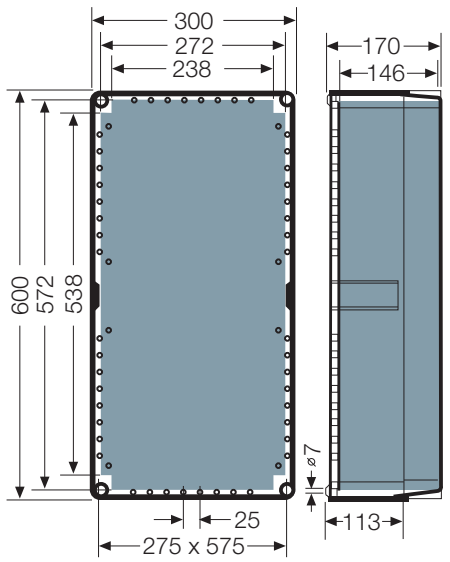

K 0400
K 0401

 = usable installation space with mounted cable glands

KG empty enclosures: temperature rise ($\Delta\theta$) by power dissipation of electrical devices

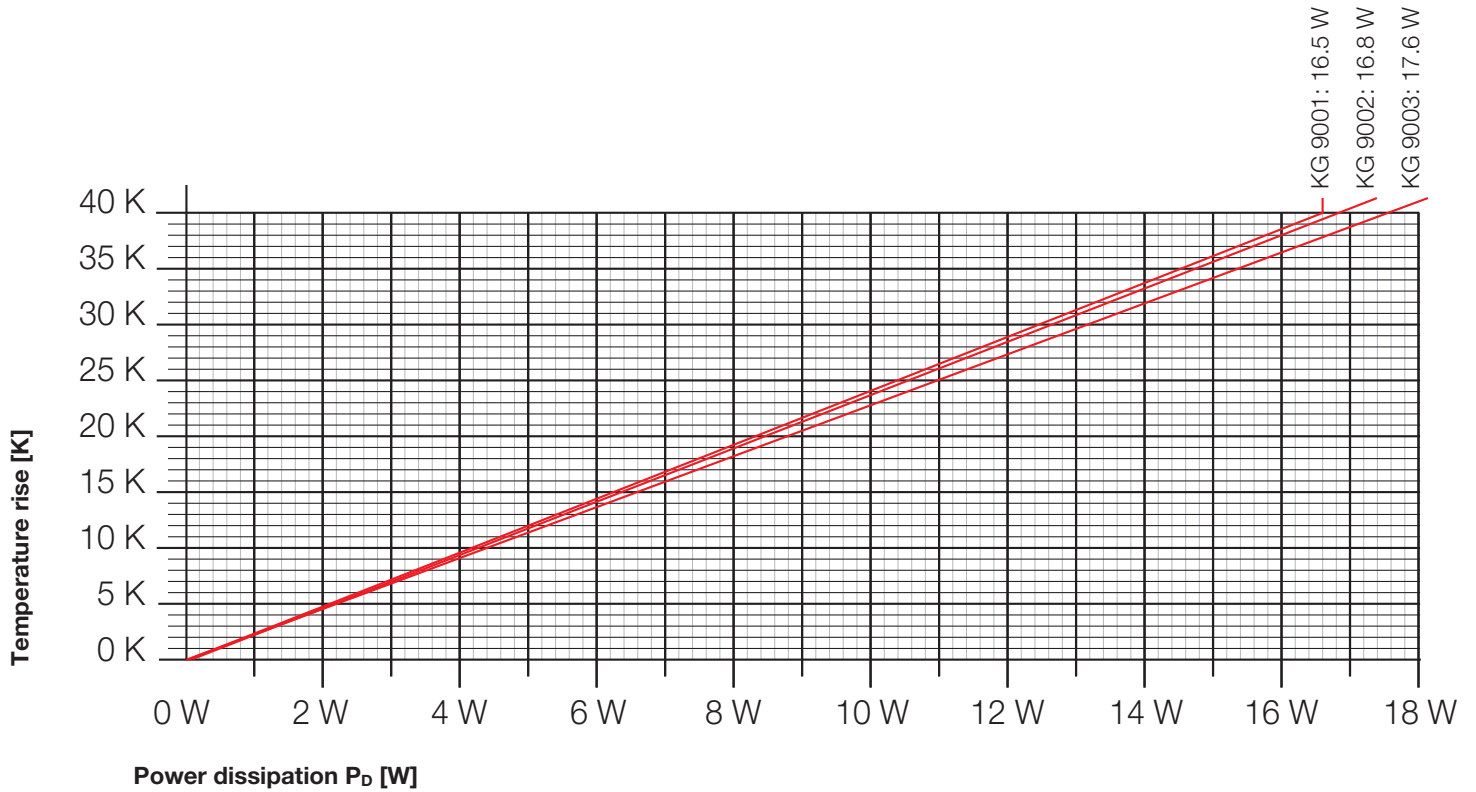

K empty enclosures: temperature rise ($\Delta\theta$) by power dissipation of electrical devices

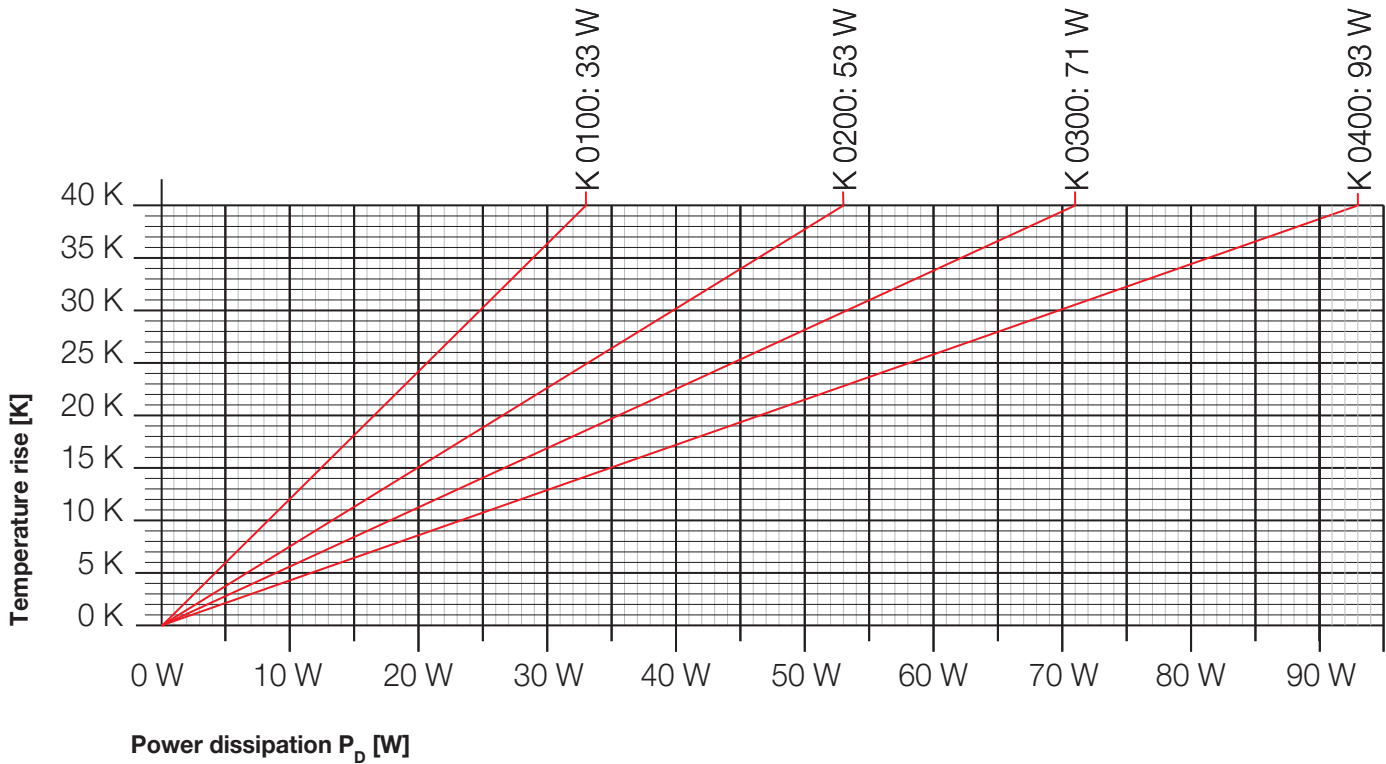

Power dissipation P_D [W]

Technical details
Operating and ambient conditions

	Empty enclosures KG	Empty enclosures K
Application area	Suitable for indoor installation and outdoor installation, protected against weather influences However, pay attention to the climatic effects on the installed equipment , for example, high or low ambient temperatures or formation of condensed water see technical information	
Ambient temperature		
- Average value over 24 hours	+35 °C	+35 °C
- Maximum value	+40 °C	+40 °C
- Minimum value	-25 °C	-25 °C
Relative humidity		
- short-time	–	50% at 40 °C 100% at 25 °C
Fire protection in the event of internal faults	Demands placed on electrical devices from standards and laws: Minimum requirements - Glow wire test in accordance with IEC 60695-2-11: - (650 ± 15) °C for boxes and cable glands	
Burning behaviour		
- Glow wire test IEC 60 695-2-11	750 °C	960 °C
- UL Subject 94	V-2 flame-retardant self-extinguishing	V-2 flame-retardant self-extinguishing
Degree of protection against mechanical load	IK 08 (5 Joule)	IK 08 (5 Joule)
Toxic behaviour	halogen-free ¹⁾ silicone-free	halogen-free ¹⁾ silicone-free
	¹⁾ “Halogen-free” in accordance with IEC 60754-2“ Common test methods for cables - Determination of the amount of halogen acid gas”. For material properties see Technical details.	