

# Instruction Bulletin

VD0C32S301B  
June 1998  
Raleigh, NC, USA

## ALTISTART® 46 Soft Start Controller User's Manual



**SQUARE D**

## DANGER

### HAZARDOUS VOLTAGE

- Read and understand this manual in its entirety before installing or operating ALTISTART 46 (ATS46) controllers. Installation, adjustment, repair, and maintenance of these controllers must be performed by qualified personnel.
- Disconnect all power before servicing controller.
- DO NOT touch unshielded components or terminal strip screw connections with voltage present.
- Install all covers before applying power or starting and stopping the controller.
- User is responsible for conforming to all applicable code requirements with respect to grounding all equipment. See Figures 1-5 on pages 5-7 for grounding points.
- Many parts in this controller, including printed wiring boards, operate at line voltage. DO NOT TOUCH. Use only electrically-insulated tools while making adjustments.

Before installing controller:

- Disconnect all power.
- Place a "DO NOT TURN ON" label on the controller disconnect.
- Lock disconnect in open position.

**Electrical shock will result in death or serious injury.**

© 1998 Square D Company. All rights reserved. This document may not be copied in whole or in part, or transferred to any other media, without the written permission of Square D.

ALTISTART and TCS are registered trademarks of Telemecanique S.A. or its successor-in-interest, Schneider Electric S.A.

InTele Braking is a trademark of Square D Company.

**CHAPTER 1—RECEIVING  
AND INSTALLATION**

INTRODUCTION .....2  
    Definition of Terms .....2  
TECHNICAL CHARACTERISTICS .....2  
DIMENSIONS AND WEIGHTS .....4  
HANDLING THE CONTROLLER .....8  
SERIAL AND MODEL NUMBERS .....8  
INSTALLATION PRECAUTIONS .....9  
MOUNTING PRECAUTIONS .....12  
    Mounting in General Purpose Metal Enclosure .....12  
    Mounting in Dust and Damp-proof Metal Enclosure .....13  
    Thermal Considerations for Sizing Enclosures .....13

**CHAPTER 2—WIRING**

WIRING .....16  
    General Wiring Practices .....16  
    Adaptation to Line Input .....16  
    Power Connections .....16  
    Bus Connection .....18  
CONTROL CONNECTIONS .....19  
    Logic Input .....21  
    Logic Outputs .....21  
    Analog Output .....21  
REMOTE MOUNTING KEYPAD .....22  
CONTROL CIRCUIT DIAGRAMS .....22  
RECOMMENDED COMPONENT LIST .....26

**CHAPTER 3—APPLICATION  
AND PROTECTION**

SOFT START APPLICATION .....30  
    Standard Duty Applications .....30  
    Heavy Duty Applications .....30  
    Reduced Torque .....30  
MODES OF STARTING .....31  
    Acceleration Ramp .....31  
    Torque Limit .....32  
    Current Limit .....32  
    Voltage Boost .....32  
MODES OF STOPPING .....32  
    Deceleration Ramp .....32  
    InTele Braking .....33  
MOTOR PROTECTION AND DIAGNOSTICS .....33  
    Thermal Overload Protection .....33  
    Excessive Cycling Prevention .....36  
    Stall and Steady State Protection .....37  
    Protection from Line Faults .....38  
CONTROLLER I/O CONFIGURATION .....38  
    Faults/ISO Contactor Control Relays .....38  
    End of Start-Up Relay .....38  
    Logic Output .....38  
    Analog Output .....39  
    Logic Input .....39  
DISPLAY OF MOTOR VALUES .....39

---

<b>CHAPTER 4—CONTROLLER SETUP AND OPERATION</b>	FACTORY PRESETS . . . . .	40
	USING THE KEYPAD . . . . .	40
	Selecting a Menu Level . . . . .	41
	Operating the Pushbuttons . . . . .	42
	ADJUSTING CONTROLLER SETTINGS . . . . .	43
	Control Parameters . . . . .	43
	Parameter Flowcharts . . . . .	45
	Setting the Motor Current . . . . .	51
	Setting the Current Limit . . . . .	51
	Advanced Acceleration Ramp Adjustments . . . . .	51
<b>CHAPTER 5—FAULT MANAGEMENT</b>	INTRODUCTION . . . . .	54
	Fault Relay Setup . . . . .	54
	Fault Display . . . . .	54
	RESETTING THE CONTROLLER . . . . .	54
	Fault Definitions . . . . .	55
	TROUBLESHOOTING FAULTS . . . . .	56
	Phase Fault . . . . .	56
	Frequency Fault . . . . .	56
	Supply Fault with Run Command Present . . . . .	57
	Motor Thermal Fault . . . . .	57
	Starter Thermal Fault . . . . .	57
	Locked Rotor Fault . . . . .	57
	Motor Underload Fault . . . . .	58
	Max Starting Time Exceeded . . . . .	58
	External Fault . . . . .	58
	Internal Serial Link Fault . . . . .	58
	Overcurrent Fault . . . . .	59
	Internal Failure Fault . . . . .	59
	Phase Inversion Fault . . . . .	59
<b>CHAPTER 6—SERVICING THE CONTROLLER</b>	INTRODUCTION . . . . .	62
	PERSONNEL PROTECTION PRECAUTIONS . . . . .	62
	LIST OF TOOLS AND INSTRUMENTS . . . . .	63
	STANDARDS . . . . .	63
	PARTS REPLACEMENT . . . . .	64
	CONTROL MODULE REPLACEMENT . . . . .	65
	POWER SECTION REPAIR . . . . .	66
	ATS46D17 to C32 Controllers . . . . .	66
	SCR Replacement . . . . .	67
	Filter Card Replacement . . . . .	69
	Thermal Switch and Fan Replacement . . . . .	69
	Control Power Transformer (CPT) Replacement . . . . .	70
	POWER SECTION REPAIR . . . . .	71
	ATS46C41N to M12 Controllers . . . . .	71
	SCR Power Pole Assembly . . . . .	71
	Firing Interface Board Replacement . . . . .	72
	Current Measurement Board Replacement . . . . .	74
	Thermal Switch Replacement . . . . .	75
	Fan Replacement . . . . .	75
	Control Power Transformer Replacement . . . . .	75





**CHAPTER 1—  
RECEIVING AND  
INSTALLATION**

---

INTRODUCTION .....	2
Definition of Terms .....	2
TECHNICAL CHARACTERISTICS.....	2
DIMENSIONS AND WEIGHTS.....	4
HANDLING THE CONTROLLER .....	8
SERIAL AND MODEL NUMBERS .....	8
INSTALLATION PRECAUTIONS .....	9
MOUNTING PRECAUTIONS.....	12
Mounting in General Purpose Metal Enclosure.....	12
Mounting in Dust and Damp-proof Metal Enclosure .....	13
Thermal Considerations for Sizing Enclosures .....	13

## INTRODUCTION

The ALTISTART 46 (ATS46) Soft Start offers state-of-the-art acceleration and deceleration control of standard three-phase asynchronous induction (squirrel cage) motors. The ATS46 controller uses a new patented technology to control the motor performance based on the motor torque rather than simple voltage- or current-based control. Advanced control algorithms are incorporated to ensure smooth rotation throughout the starting ramp without mechanical instability at the end of starting.

A microprocessor continuously monitors the motor and controller performance to provide maximum protection of the controller, motor, and driven machinery. A variety of starting and stopping modes are standard. A digital keypad provides accurate controller setup and continuous motor performance display.

The ATS46 motor controller is available in 21 current ratings from 17 to 1200 amps. All models use a common control module for consistent and simple set up. ATS46 controllers are rated for use with 208/230, 380/400, or 460/500 V motors, and are self-adjusting for a 50 or 60 Hz supply frequency.

## Definition of Terms

Some of the terms and acronyms used in this manual are defined in Table 1.

**Table 1: Definition of Terms**

Term	Definition
FLA	Full load amps: the current rating of an induction motor at rated speed and load. This value may be found on the motor nameplate.
$I_{CL}$	Nominal current rating of the ATS46 controller. This value may be found on the controller nameplate.
$I_n$	User defined motor current rating. Same as FLA.
$T_n$	Nominal motor torque as calculated by ATS46 controller.
$V_n$	Nominal voltage of supply power (mains supply). This should correspond to the motor rated voltage found on the motor nameplate.

## TECHNICAL CHARACTERISTICS

The following tables describe the technical characteristics of the ALTISTART 46.

**Table 2: Environmental Characteristics**

Degree of protection	IP 20:ATS-46D17N to 46C14N starters IP 00:ATS-46C17N to 46M12N starters
Shock resistance	Conforms to IEC 68-2-27: 15g, 11 ms:ATS-46D17N to 46D38N starters
Vibration resistance	Conforms to IEC 68-2-6, NFC 20706 and BV1
Resistance to electrostatic discharges	Conforms to IEC 1000-4-2 - level 3
Immunity to radio-electric interference	Conforms to IEC 1000-4-3 - level 3
Immunity to rapid electrical transients	Conforms to IEC 1000-4-4 - level 4
Ambient air temperature	Operation: 0 to +40 °C without de-rating (between +40 °C and +60 °C, de-rate the ATS46 current by 1.2% for each °C) Storage: -25 ° to +70 °C
Maximum relative humidity	93% without condensation or dripping water
Maximum ambient pollution	Degree 3 conforming to IEC 664
Maximum operating altitude	1000 m without de-rating (above this, de-rate the ATS46 current by 0.5% for each additional 100 m)
Operating position	Maximum vertical inclination $\pm 15^\circ$ with respect to the normal mounting position
Degree of protection	IP 20:ATS-46D17N to 46C14N starters IP 00:ATS-46C17N to 46M12N starters



**Table 3: Electrical Characteristics**

Three-phase supply voltage	208 V -10% to 240 V +10% 380 V -15% to 415 V +10% 440 V -10% to 500 V +10%
Frequency	50 Hz $\pm$ 2.5 Hz or 60 Hz $\pm$ 3.6 Hz, self-adjusting
Rated current (I <sub>CL</sub> )	17 to 1200 A in 21 ratings
Motor power	2 to 1000 hp
Motor voltage	208-220-230-240-380-440-460-500 V
Protection	Integrated thermal protection for motor and controller.
- Mains protection	Phase failure signaled by LED and output relay. Controller stops.
- Thermal switches	Controllers rated 75 amps and above have two thermal switches, one controlling the fan (50C), and one protecting against controller overheating (90C or 105C).
Three-phase supply voltage	208 V -10% to 240 V +10% 380 V -15% to 415 V +10% 440 V -10% to 500 V +10%

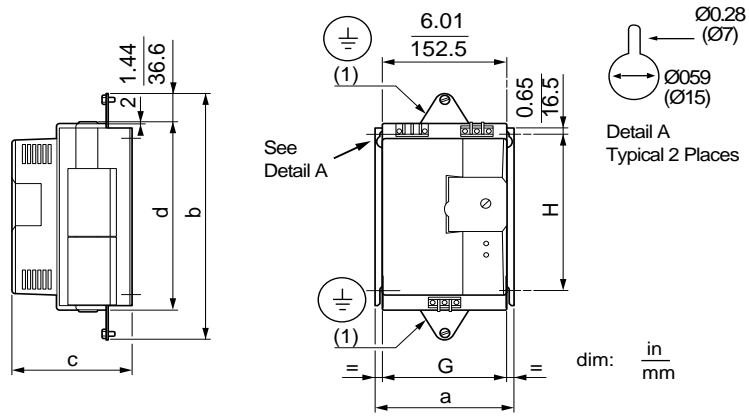
**Table 4: Control Terminal Blocks**

J1 Terminals	Function	Characteristics
STOP RUN	Stop controller Run controller	3 logic inputs with 1.5 k $\Omega$ impedance V <sub>max</sub> = 30 V, I <sub>max</sub> = 16.5 mA state 1: V > 11 V - I > 6 mA state 0: V < 5 V - I < 2 mA
LI	Logic input (assignable)	
PL	Supply to logic inputs	+ 24 V $\pm$ 5 V isolated and not protected against short circuits and overloads; maximum: 60 mA
LO+	Supply to logic outputs	Connect to PL or to an external supply
LO1	Logic outputs	Logic outputs compatible with PLC inputs
LO2		V <sub>max</sub> = 40 V, V <sub>min</sub> = 10 V; maximum current: 200 mA with external supply
AO1	Analog output	0-20 mA, linearity 3%, precision 3% maximum impedance 800 $\Omega$
COM	Logic input, logic output, and analog output common	0 V
<b>J2 Terminals</b>		
R1B R1D	N/C contact of relay R1	Minimum switching capacity: 100 mA-24 VDC Maximum operating voltage: 400 V
R1A R1C	N/O contact of relay R1	Rated operating current: 0.5 A Inductive: 240 VAC or 48 VDC 5A Resistive: 240 VAC or 48 VDC
R2A R2C	N/O contact of relay R2 Control of shorting contactor	

**Table 5: Short Circuit Protection (Type 1)**

Altistart Model	With Power Fusing			With Thermal Magnetic Circuit Breaker	
	Fuse Class	Max Amp Rating	Fault Current Withstand Rating (A rms sym)	Max Amp Rating	Fault Current Withstand Rating (A rms sym)
ATS46D17N	RK5	30	65,000	30	5,000
ATS46D22N	RK5	40	65,000	40	5,000
ATS46D32N	RK5	50	65,000	50	5,000
ATS46D38N	RK5	60	65,000	60	5,000
ATS46D47N	RK5	75	65,000	80	5,000
ATS46D62N	RK5	100	65,000	90	5,000
ATS46D75N	RK5	125	65,000	100	10,000
ATS46D88N	RK5	150	65,000	110	10,000
ATS46C11N	RK5	200	65,000	150	10,000
ATS46C14N	RK5	250	65,000	200	10,000
ATS46C17N	RK5	300	65,000	225	18,000
ATS46C21N	RK5	350	65,000	250	18,000
ATS46C25N	RK5	450	65,000	350	18,000
ATS46C32N	RK5	600	65,000	450	18,000
ATS46C41N	L	650	65,000	600	18,000
ATS46C48N	L	750	65,000	600	30,000
ATS46C59N	L	1000	65,000	800	30,000
ATS46C66N	L	1200	65,000	900	30,000
ATS46C79N	L	1350	65,000	-	-
ATS46M10N	L	1500	65,000	-	-
ATS46M12N	L	1600	85,000	-	-

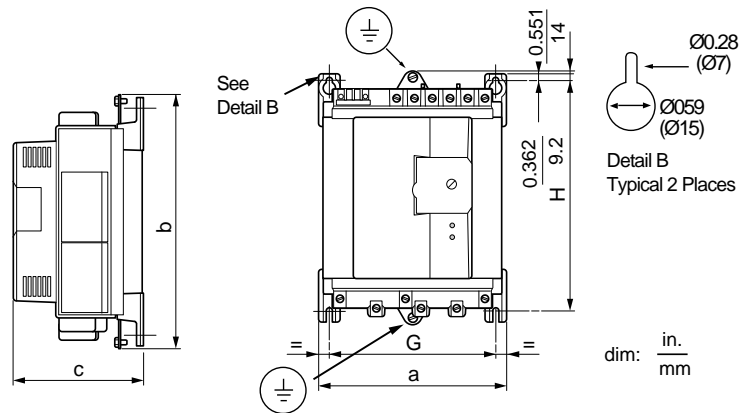
DIMENSIONS AND WEIGHTS



(1) Removable earth boss, supplied with product but not fitted.

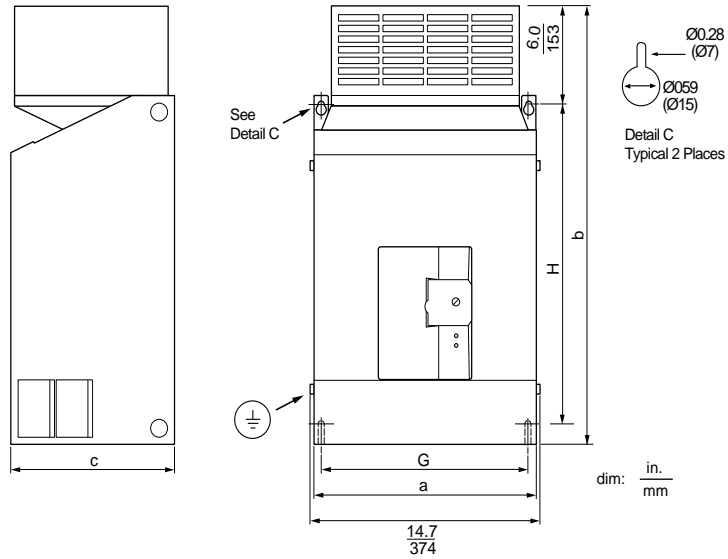
	a		b		c		d		G		H		weight	
	in	mm	in	mm	in	mm	in	mm	in	mm	in	mm	lb	kg
ATS46D17N	6.70	170	12.84	326	5.95	151	9.93	252	5.91	150	8.27	210	9.04	4.10
ATS46D22N	6.70	170	12.84	326	5.95	151	9.93	252	5.91	150	8.27	210	9.04	4.10
ATS46D32N	6.70	170	14.81	376	5.95	151	11.90	302	5.91	150	10.24	260	9.7	4.40
ATS46D38N	6.70	170	14.81	376	5.95	151	11.90	302	5.91	150	10.24	260	9.7	4.40

Figure 1: ATS46D17N to D38N Dimensions



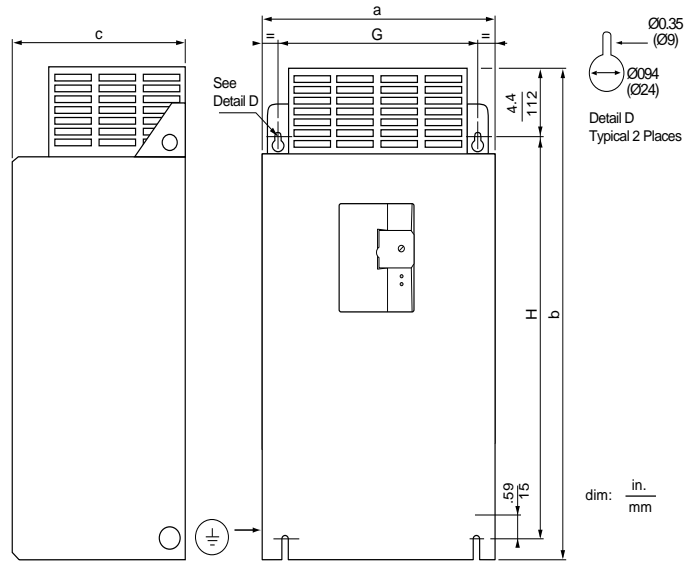
	a		b		c		G		H		weight	
	in	mm	in	mm	in	mm	in	mm	in	mm	lb	kg
ATS46D47N	9.45	240	13.00	330	6.58	167	8.35	212	11.82	300	15.21	6.90
ATS46D62N	9.45	240	13.00	330	6.58	167	8.35	212	11.82	300	15.21	6.90
ATS46D75N	9.45	240	13.40	340	9.61	244	8.35	212	11.82	300	23.59	10.70
ATS46D88N	9.45	240	13.40	340	9.61	244	8.35	212	11.82	300	23.59	10.70
ATS46C11N	9.45	240	15.37	390	9.61	244	8.35	212	13.79	350	26.24	11.90
ATS46C14N	9.45	240	17.34	440	9.61	244	8.35	212	15.76	400	35.28	16.00

Figure 2: ATS46D47N to C14N Dimensions



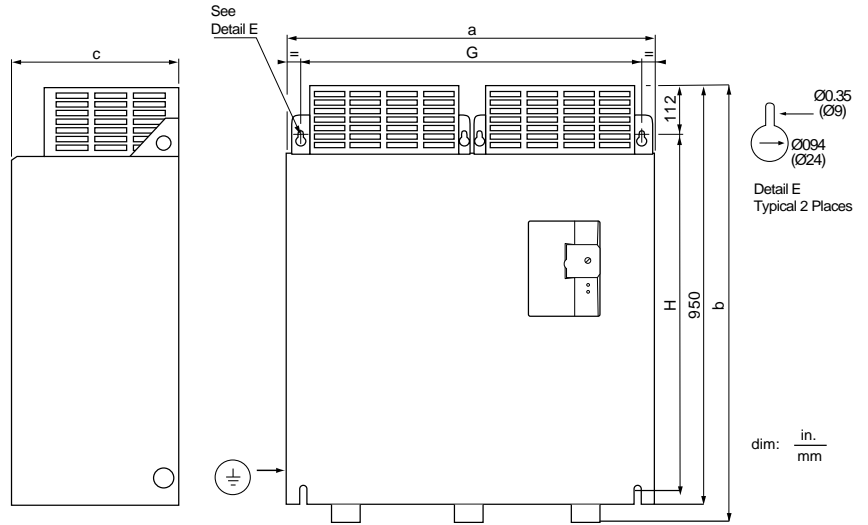
	a		b		c		G		H		weight	
	in	mm	in	mm	in	mm	in	mm	in	mm	lb	kg
ATS46C17N	14.34	364	26.99	685	10.60	269	13.36	339	19.70	500	97.02	44.00
ATS46C21N	14.34	364	26.99	685	10.60	269	13.36	339	19.70	500	97.02	44.00
ATS46C25N	14.34	364	26.99	685	10.60	269	13.36	339	19.70	500	97.02	44.00
ATS46C32N	14.34	364	26.99	685	10.60	269	13.36	339	19.70	500	97.02	44.00

Figure 3: ATS46C17N to C32N Dimensions



	a		b		c		G		H		weight	
	in	mm	in	mm	in	mm	in	mm	in	mm	lb	kg
ATS46C41N	15.8	401	37.4	950	13.9	353	13.2	335	31.5	800	123	56
ATS46C48N	15.8	401	37.4	950	13.9	353	13.2	335	31.5	800	137	62
ATS46C59N	15.8	401	37.4	950	13.9	353	13.2	335	31.5	800	137	62
ATS46C66N	15.8	401	37.4	950	13.9	353	13.2	335	31.5	800	137	62

Figure 4: ATS46C41N to C66N Dimensions



	a		b		c		G		H		weight	
	in	mm	in	mm	in	mm	in	mm	in	mm	lb	kg
ATS46C79N	30	766	40	1012	14	353	27.5	700	31.5	800	247	112
ATS46M10N	30	766	40	1012	14	353	27.5	700	31.5	800	273	124
ATS46M12N	30	766	40	1012	14	353	27.5	700	31.5	800	273	124

Figure 5: ATS46C79N to M12N Dimensions

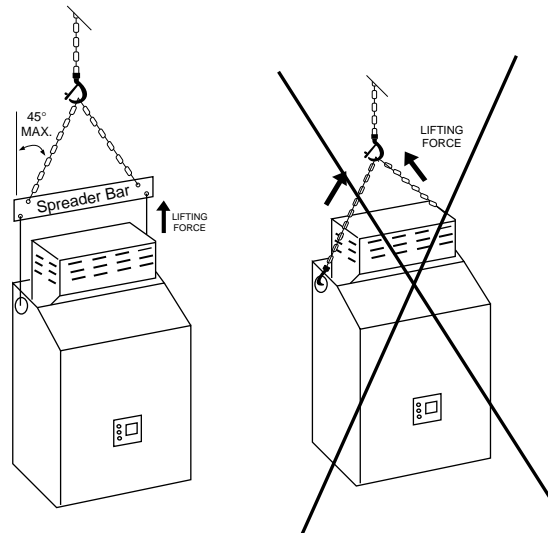
## HANDLING THE CONTROLLER

Do not remove the ALTISTART 46 (ATS46) controller from the carton until it is at the final installation site. The carton provides protection and prevents damage to the controller's exterior. Handle the controller carefully after removing it from the carton to avoid damage to the internal components, frame or exterior. Once removed from the carton, the controller can be handled:

- With a hoist. When hoisting the controller, attach a spreader bar to the two lifting rings on top of the controller as shown in Figure 6.
- In a horizontal position, with the back of the controller resting on a pallet.

*NOTE: Do not rest unit directly on bus bar connectors.*

<b>▲ WARNING</b>
<b>HANDLING AND LIFTING HAZARD</b>
Keep area below any equipment being lifted clear of all personnel and property. Use lifting method shown in left-hand portion of Figure 6.
<b>Failure to follow this instruction can result in death or serious injury.</b>



**Figure 6: Hoisting the ATS46 Controller**

## SERIAL AND MODEL NUMBERS

The serial and model numbers of the ATS46 controller appear on the bar code sticker located on the front right side of the component.



Record the serial number below. This number will assist us in helping you in the future:

Serial Number: 6W _____
-------------------------

## INSTALLATION PRECAUTIONS

Follow these precautions when installing the ATS46 controller:

### **⚠ DANGER**

#### **HAZARDOUS VOLTAGE**

- Read and understand this manual in its entirety before installing or operating ATS46 controllers. Installation, adjustment, repair, and maintenance of these controllers must be performed by qualified personnel.
- Disconnect all power before servicing the controller.
- DO NOT touch unshielded components or terminal strip screw connections with voltage present.
- Install all covers before applying power or starting and stopping the controller.
- User is responsible for conforming to all applicable code requirements with respect to grounding all equipment. See Figures 1-5 on pages 5-7 for grounding points.
- Many parts in the controller, including printed wiring boards, operate at line voltage. DO NOT TOUCH. Use only electrically-insulated tools while making adjustments.

Before installing the controller:

- Disconnect all power.
- Place a "DO NOT TURN ON" label on the controller disconnect.
- Lock disconnect in open position.

**Electrical shock will result in death or serious injury.**

- Voltage and frequency specifications for the input line must match the controller configuration.
- A disconnect switch must be installed between the input line and the controller.

### **⚠ DANGER**

#### **HAZARDOUS VOLTAGE**

- The solid-state switches of the ATS46 controller power circuit do not provide complete isolation from the line. Due to leakage currents through the solid-state switches, hazardous voltages can be present on the controller load-side power circuit whenever power is applied to the line side of the controller.
- Disconnect all power before servicing the controller or motor.

**Electrical shock will result in death or serious injury.**

- When using an isolation contactor, certain sequencing must be observed with respect to the run signal supplied to the ATS46 controller. During starting of the controller, closure of the isolation contactor generally should precede or coincide with the application of the controller run command. If line power is not detected at the L1, L2, and L3 terminals of the controller within 500 ms of this run command, a "Phase Failure" fault will occur. The circuit diagrams use this feature of the controller, as displayed in Figures 21 and 22.
- External overcurrent protection devices (OCPD) in the form of fuses or a circuit breaker must be installed on the line-side connections of the ATS46 controller. The maximum recommended OCPD rating, along with the associated controller short-circuit withstand rating, is listed in Appendix A.

## **⚠ WARNING**

### **OVERCURRENT DEVICES MUST BE PROPERLY COORDINATED**

- OCPD must be installed on the line-side of the ATS46 controller to achieve published short-circuit withstand ratings.
- Do not exceed the maximum OCPD ratings shown in Appendix A.
- Do not connect the controller to a power feeder whose short circuit capacity exceeds the controller short circuit withstand rating shown in Appendix A.

**Failure to follow this instruction can result in death or serious injury.**

- Power factor correction capacitors should not be connected to a motor controlled by an ATS46 controller. If power factor correction is required, the capacitors must be located on the line-side of the controller. A separate contactor should be used to switch the capacitors off when the motor is off, or during acceleration and deceleration.

## **⚠ CAUTION**

### **EQUIPMENT DAMAGE HAZARD**

Do not connect power factor correction capacitors to the load-side power circuit of the ATS46 controller.

**Failure to follow this instruction can result in injury or equipment damage.**

- The ATS46 controller uses solid-state power switches to control motor power. When checking the condition of conductor or motor insulation, do not connect the high potential dielectric test equipment or insulation resistance tester to the controller since the test voltages used may damage the controller. Always disconnect the controller from the conductors or motor before performing such tests.

## **⚠ CAUTION**

### **EQUIPMENT DAMAGE HAZARD**

- Do not perform high potential dielectric tests on circuits while the circuits are connected to the ATS46 controller.
- Any circuit requiring high potential dielectric tests must be disconnected from the controller prior to performing the test.

**Failure to follow this instruction can result in injury or equipment damage.**

- The ATS46 controller contains electronic protection to detect and signal failure of the solid-state switches.
- Since the solid-state switches may be incapable of completely blocking motor power should a failure occur, auxiliary isolation on the line-side of the controller is required. The isolation device must be capable of operation via command from the Fault relay of the controller. An isolation device consisting of either a circuit breaker incorporating a shunt trip coil or an electromagnetic contactor can be used to open the controller power circuit in the event of a controller fault.

Refer to Figures 20 through Figures 22 on pages 22 through 24 for typical circuit diagrams that display the logic controlling the isolation device via the fault relay.



## **⚠ CAUTION**

### **MOTOR OVERHEATING**

Failure of the solid-state switches on the ATS46 controller can cause single-phase operation of the motor.

- Use an isolation device consisting of either a circuit breaker equipped with a shunt trip coil or an electromagnetic contactor to open the line-side of the controller.
- The isolation device must be capable of interrupting motor locked rotor current.
- Connect the fault relay of the controller to open the isolation device in the event of a controller fault.

**Failure to follow this instruction can result in injury or equipment damage.**

## **⚠ WARNING**

### **BRANCH CIRCUIT CONDUCTOR HAZARD**

If System grounding is not adequate to ensure ground fault levels exceed 1300% of motor full load amps (FLA), then this device may not ensure protection of branch circuit conductors. In this case, external ground fault protection must be properly coordinated. Recommended solutions include:

- Time delay fuses coordinated to 125% of motor FLA. Fuses listed in Recommended Component List on page 26 are sized to ensure proper coordination and may be used for applications that do not require start times longer than 50 seconds at 300% current limit or 20 seconds at 500% current limit.
- Equipment ground fault protection. If using a circuit breaker or fuses sized larger than 125% of motor FLA as OCPD, an external ground fault relay or circuit breaker with ground fault detection should be coordinated with controller. An application diagram showing coordination of an equipment ground fault relay is shown in Figure 20 on page 22.
- External overload relay. For multi-motor applications, applications in which motor does not match the controller size, or applications that use a full voltage bypass scheme, an external overload relay can be coordinated to protect conductors from a high-impedance ground fault.

**Failure to follow this instruction can result in death or serious injury.**

## MOUNTING PRECAUTIONS

Follow these precautions when mounting the ATS46 controller:

- Controllers are open devices and must be installed in suitable enclosures or controlled access areas. The environment around the controller must meet Pollution Degree 3 requirements as defined in NEMA ICS1-1 or IEC 664-1.

### **⚠ DANGER**

#### **HAZARDOUS VOLTAGE**

ATS6 controllers are open devices and must be mounted in a suitable enclosure.

**Electrical shock will result in death or serious injury.**

- When installation surface is not even, put a spacer behind the controller mounting pads to eliminate gaps. Fastening the controller exterior to an uneven surface may damage the controller.
- When installing in an enclosure, cover the device to prevent metallic debris from falling into the controller.
- The ATS46 controller generates heat and must be properly ventilated. Refer to “Thermal Considerations for Sizing Enclosures” on page 13 to determine power dissipated.
- When several controllers are installed in a control panel, arrange them in a row. Do not stack controllers. Heat generated from the bottom controller can adversely affect the ambient temperature around the top controller.

### **⚠ CAUTION**

#### **CONTROLLER OVERHEATING**

- Mount the ATS46 controller within  $\pm 15\%$  of vertical.
- Do not locate the controller near heat radiating elements.
- Electrical current through the controller will result in heat losses that must be dissipated into the ambient air immediately surrounding the controller. To prevent thermal fault or equipment damage, provide sufficient enclosure cooling and/or ventilation to limit the ambient temperature around the controller.

**Failure to follow this instruction can result in injury or equipment damage.**

## Mounting in General Purpose Metal Enclosure

Degree of protection: NEMA Type 1 (IP23). To ensure adequate air flow inside the controller, follow these guidelines:

- Leave sufficient space around the controller (see Figure 7):  $A \geq 2$  in (50 mm),  $B \geq 4$  in (100 mm).
- Provide ventilation.
- Ensure sufficient ventilation. If necessary, install a cooling fan with filters.

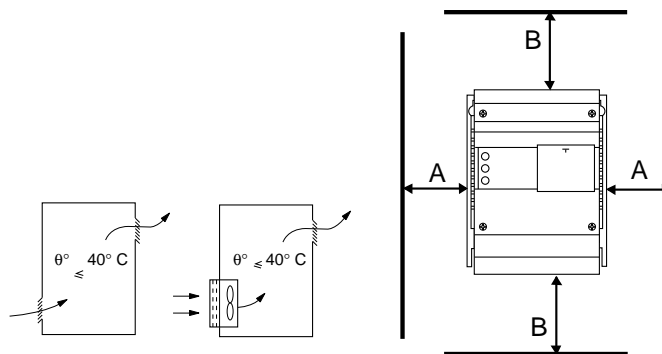


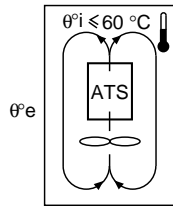
Figure 7: Ventilation and Clearances

**Mounting in Dust and Damp-proof Metal Enclosure**

Degree of protection: NEMA Type 12 (IP54). Provide a stirring fan to circulate air inside the enclosure and prevent hot spots in the controller. This allows operation of the controller in an enclosure with a maximum internal temperature of 140 °F (60 °C). De-rate the controller current  $I_n$  by 1.2% per °C for temperatures above 40 °C or, where applicable, use a shorting contactor (duty cycle not to exceed 2 starts per hour). Do not use insulated or non-metallic enclosures as they have poor thermal conduction.

Locate the fan and ensure that ambient temperature around the controller is within the specifications.

To reduce temperature rise within the enclosure, use a shorting contactor (47 A units and higher). Use a heat exchanger when necessary to keep internal temperatures within specification.



**Figure 8: Ventilation for Dust and Damp-proof Enclosure**

**Thermal Considerations for Sizing Enclosures**

When mounting the ATS46 controller in an enclosure, use the enclosure manufacturers' recommendations for proper sizing based on thermal considerations. For this, it is necessary to sum the power dissipated by each device within the enclosure. Table 6 lists the steady state power dissipation for the ATS46 controller operating at rated current.

**Table 6: Power Dissipated by Controllers at Rated Current**

Controller Reference	Power in W	Controller Reference	Power in W
ATS46D17N	72	ATS46C21N	670
ATS46D22N	79	ATS46C25N	795
ATS46D32N	109	ATS46C32N	973
ATS46D38N	121	ATS46C41N	1404
ATS46D47N	158	ATS46C48N	1452
ATS46D62N	206	ATS46C59N	1800
ATS46D75N	255	ATS46C66N	2025
ATS46D88N	296	ATS46C79N	2680
ATS46C11N	342	ATS46M10N	3010
ATS46C14N	411	ATS46M12N	3640
ATS46C17N	550		

REMOTE MOUNTING  
KEYPAD

Part number VW3G46103 includes all hardware necessary to mount the display module in a remote location up to three meters from the ATS46 controller. When mounted externally, the protection index of the display module is IP65 suitable for use on a TYPE 12 enclosure.



---

**CHAPTER 2—WIRING**

WIRING . . . . .	16
General Wiring Practices . . . . .	16
Adaptation to Line Input . . . . .	16
Power Connections . . . . .	16
Bus Connection . . . . .	18
CONTROL CONNECTIONS . . . . .	19
Logic Input . . . . .	21
Logic Outputs . . . . .	21
Analog Output . . . . .	21
REMOTE MOUNTING KEYPAD . . . . .	22
CONTROL CIRCUIT DIAGRAMS . . . . .	22
RECOMMENDED COMPONENT LIST . . . . .	26

## WIRING

Good wiring practice requires the separation of control circuit wiring from all power (line and load) wiring. Power wiring to the motor must have the maximum possible separation from all other power wiring. **Do not run in the same conduit**; this separation reduces the possibility of coupling electrical noise between circuits.

### General Wiring Practices

When wiring ATS46 controllers, follow the wiring practices required by national and local electrical codes. In addition, follow these guidelines:

- Use metallic conduit for all controller wiring. Do not run control and power wiring in the same conduit.
- Separate metallic conduits carrying power wiring or low-level control wiring by at least 3 in (8 cm).
- Separate non-metallic conduits or cable trays used to carry power wiring from metallic conduit carrying low-level control wiring by at least 12 in (30.5 cm).
- Cross the metallic conduits and non-metallic conduits at right angles whenever power and control wiring cross.

### Adaptation to Line Input

The control circuit is completely independent of the power circuit. To select control voltage, follow the instructions on the label located on the top of the controller:

- 208-240 V: move terminal cover from position 230 to position 460/500 V and connect single phase voltage supply to terminals C and 230 V.
- 380-415 V: move terminal cover from position 400 to position 460/500 V and connect single phase voltage supply to terminals C and 400 V.
- 440-500 V: check that exposed control terminals are marked C and 460/500 V. If not, move blue terminal cover from 460/500 V terminal and connect single phase voltage supply to terminals C and 460/500 V.

The power circuit adapts automatically to the input line voltage over a range of 208 to 500 V ( $\pm 10\%$ ) for standard controllers.

### Power Connections

**Table 7: Wire Size and Tightening Torque**

	ATS46	D17N - D38N	D47N - C14N	C17N - C32N	C41N - C66N	C79N - M12N
POWER CONNECTIONS:						
L1 / L2 / L3 A1 / B1 / C1 T1 / T2 / T3 A2 / B2 / C2	Max Wire Size AWG [1]	8	2/0	Bus Bar	Bus Bar	Bus Bar
	Tightening Torque lb-in [2]	15	88	500	500	500
	Recommended Mounting Screw [3]	n/a	n/a	1/2 - 13	1/2 - 13	1/2 - 13
CONTROL POWER CONNECTIONS:						
C 230 400 460/500	Max Wire Size AWG	12	12	12	12	12
	Tightening Torque lb-in	10.5	10.5	5.2	5.2	5.2
GROUND CONNECTIONS:						
⏚	Ground Screw Supplied	M4	M6	M10	M10	M10
	Tightening Torque lb-in[4]	15	25.6	238	238	238

[1] Power terminals suitable for use with 75 °C rated conductors; copper only.

[2] Power terminals on controllers ATS46D17N through C14N require metric hex wrenches. The appropriate size hex wrench is provided with these controllers.

[3] Requires user-supplied lug and fastener.

[4] Requires user-supplied lug.

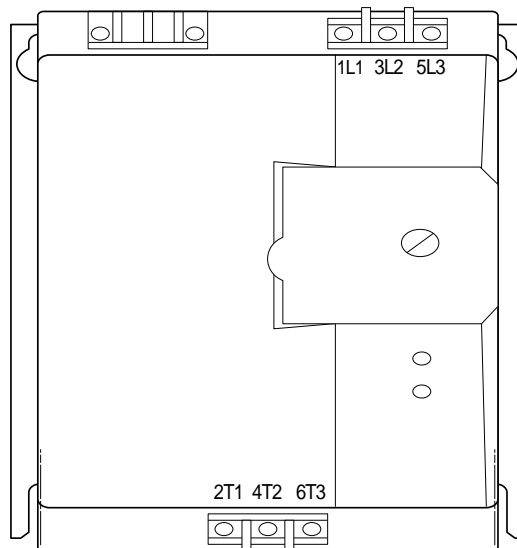


Figure 9: Power Connections ATS46D17N to D38N

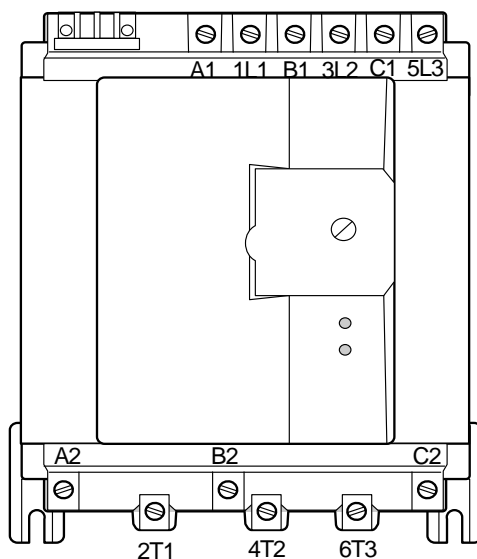


Figure 10: Power Connections ATS46D47N to C14N

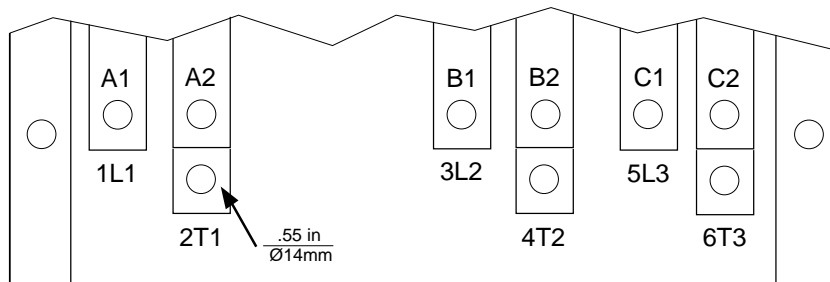
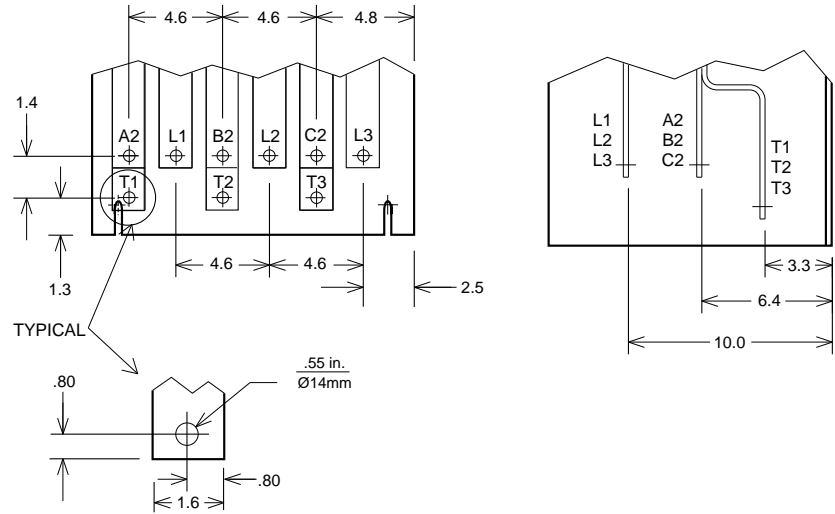
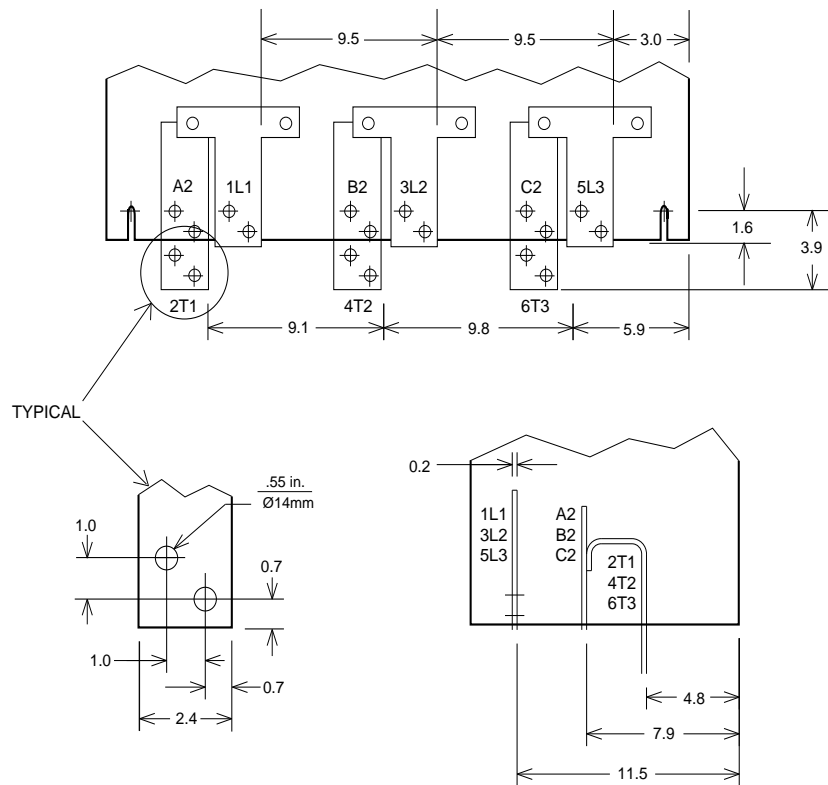


Figure 11: Bus Bar Power Connections ATS46C17N to C32N

**Bus Connection  
Dimensions (inches)**



**Figure 12: Bus Power Connection Dimensions: ATS46C41N to C66N**



**Figure 13: Bus Connection Dimensions: ATS46C79N to M12N**



CONTROL CONNECTIONS

Although all control inputs and outputs of the controller are isolated from the input lines, follow these control wiring precautions:

- Keep control wiring conductor runs short and direct.
- Ensure that the control contacts used with the controller inputs are rated for operation at open circuit voltages of 24 VDC and closed circuit currents of 10 mADC.
- The analog output requires twisted cable with a pitch of 1–2 inches. Use a cable shield. The shield must be terminated to ground at one end only.
- Ensure that the coils of all relays and solenoids connected to the output contacts of the controller are equipped with appropriate transient suppressors.
- For proper control wiring, route conductors to avoid contact with other voltage potentials in the controller. Wire insulation must have the appropriate voltage rating for the voltage present.

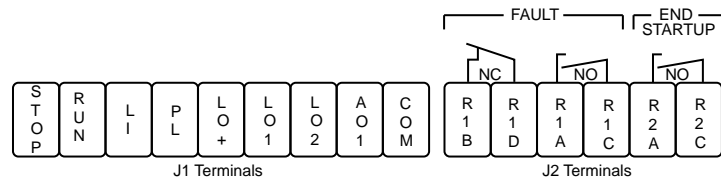


Figure 14: ATS46 Control Terminal Connections

Table 8: J1 Terminal Connection

J1 TERMINAL	TYPE	FUNCTION	DESCRIPTION
STOP	Input	Stop	Controller will allow motor to run when this connection is made to terminal PL. Both RUN and STOP connections must be removed to initiate a stop command. See Figure 15 on page 20 for connection of interlocking contacts, if used.
RUN	Input	Run	Controller will start motor when connection is made between this point and PL. This connection may be momentary.
LI	Configurable Logic Input	Preset for force to freewheel stop	Controller will respond when connection is made between this point and PL. Refer to "Logic Input" on page 11 for available configurations.
PL	Supply to Inputs		24 volt supply for use with J1 terminal connections only
LO+	Supply to Logic Outputs		Connect to PL or to external 24 volt supply. Maximum current with external supply: 200 mA
LO1	Configurable Logic Output	Preset for indication of motor thermal alarm	Logic output compatible with PLC input or LED type pilot light. May also be configured to indicate motor current is present.
LO2	Logic Output	Current threshold alarm	Logic output compatible with PLC input or LED type pilot light.
AO1	Configurable Analog Output	Preset for 0-20 mA indication of motor current	Analog output may be scaled for 0-20 mA or 4 -20 mA output of motor status. Connect appropriate meter from AO1 to COM.
COM	Logic input, logic output and analog output common		0 V reference

Refer to Table 3 on page 3 for electrical characteristics.

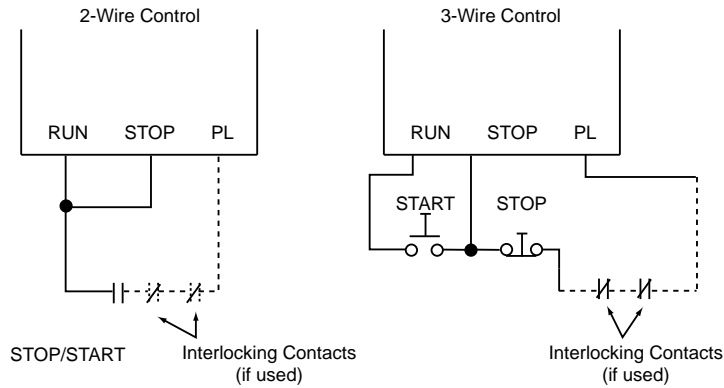


Figure 15: Interlocking Contact Connection

Table 9: J2 Terminal Connections

J2 TERMINAL	TYPE	FUNCTION	DESCRIPTION
R1B - R1D R1A - R1C	Relay Output	N.C. - Fault N.O. - Fault	May be configured for fault indication or for control of isolation contactor. Normal state of relay is the state with all power removed from the controller or if a fault is detected. When configured for fault indication, contacts will energize after successful completion of internal diagnostics and will de-energize if a fault is detected. If configured for control of an isolation contactor, relays will energize after a run command is issued and de-energize after deceleration is complete or if a fault is detected. If using automatic restart, the status of the fault relay is dependent on the type of fault and configuration of the R1 relay. Refer to Chapter 4 for Fault relay status, if using automatic restart.
R2A - R2C	Relay Output	N.O. - End of Start-up	Relay contact will close when the controller has completed the acceleration ramp and the current draw of the motor is less than 130% of the motor FLA (or the setting of $I_n$ ) setting. Contact is coordinated with the thyristors on a stop command or fault condition. This relay is typically used to control a contactor that bypasses the controller after start-up to ease thermal management of the installation. If a shorting contactor is not used, the status of this relay may be indeterminate following a phase failure fault.

Refer to Table 3 on page 3 for electrical characteristics.

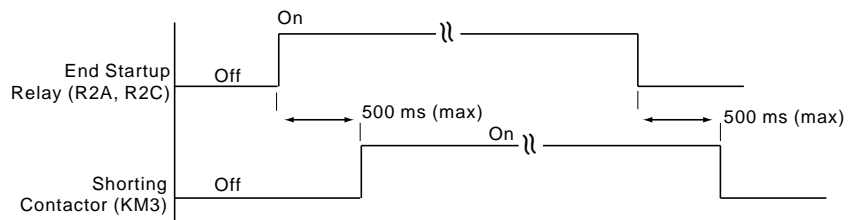
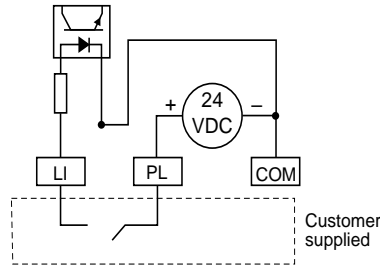


Figure 16: Shorting Contactor Timing Diagram

**Logic Input**

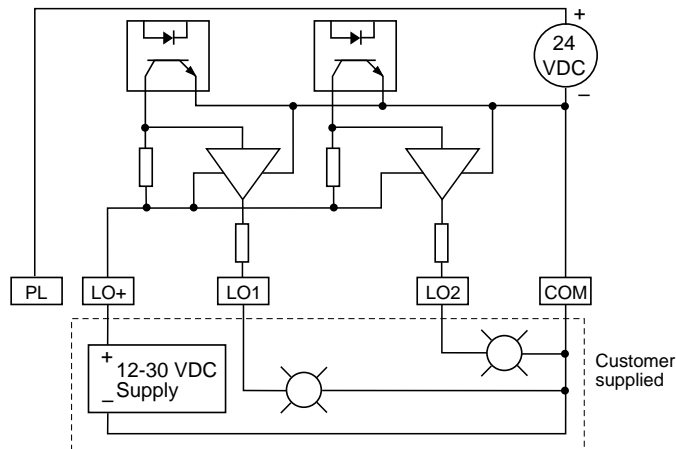
The logic input (LI) may be operated either from the internal supply or an external supply. Figure 17 shows the connections for operating the logic input from an internal supply.



**Figure 17: Operating the Logic Inputs from Internal Power Supply**

**Logic Outputs**

The logic outputs (LO+, LO1, LO2) can be operated from either the internal supply or an external supply. The maximum current with external supply is limited to 200 mA. If the internal supply is used, LO+ must be connected to PL. Figure 18 shows the connection of an external supply for operating the logic outputs



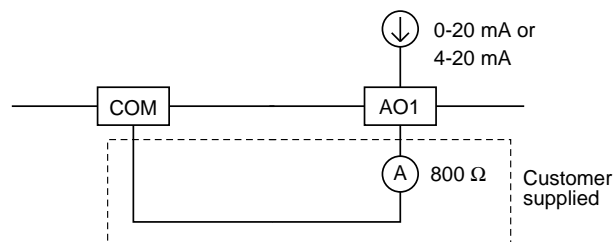
**Figure 18: Operating the Logic Outputs from External Power Supply**

**Analog Output**

The analog output (AO1) can be configured for 0-20 or 4-20 mA output of the motor current, torque, thermal state, or power factor. Refer to Chapter 3 for configuration of the analog output.

The maximum driving voltage is +12 V with an internal impedance of 800 Ω.

Figure 19 shows the connection of an external meter to the analog output.



**Figure 19: Analog Outputs**



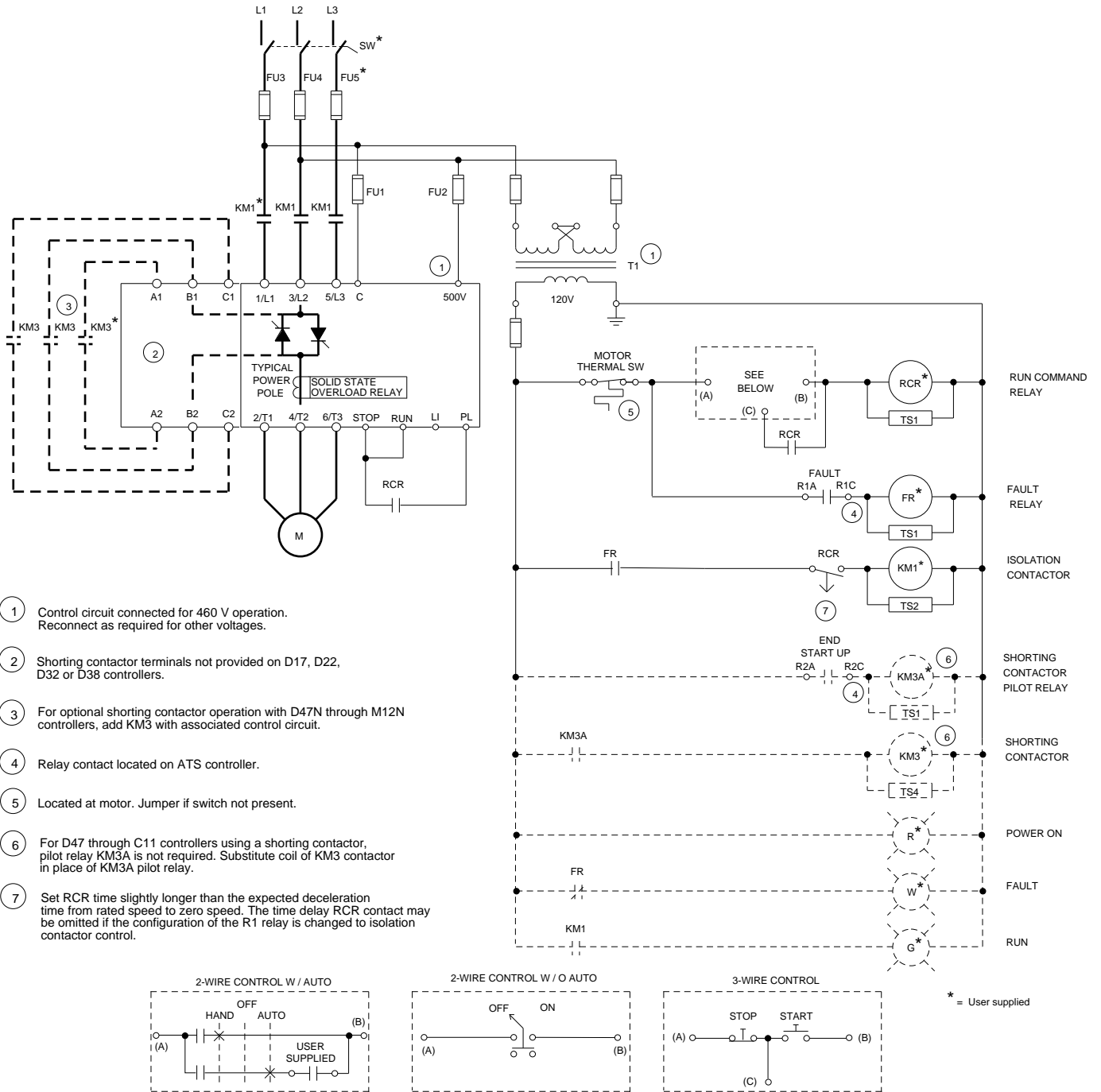


Figure 21: Nonreversing with Isolation Contactor

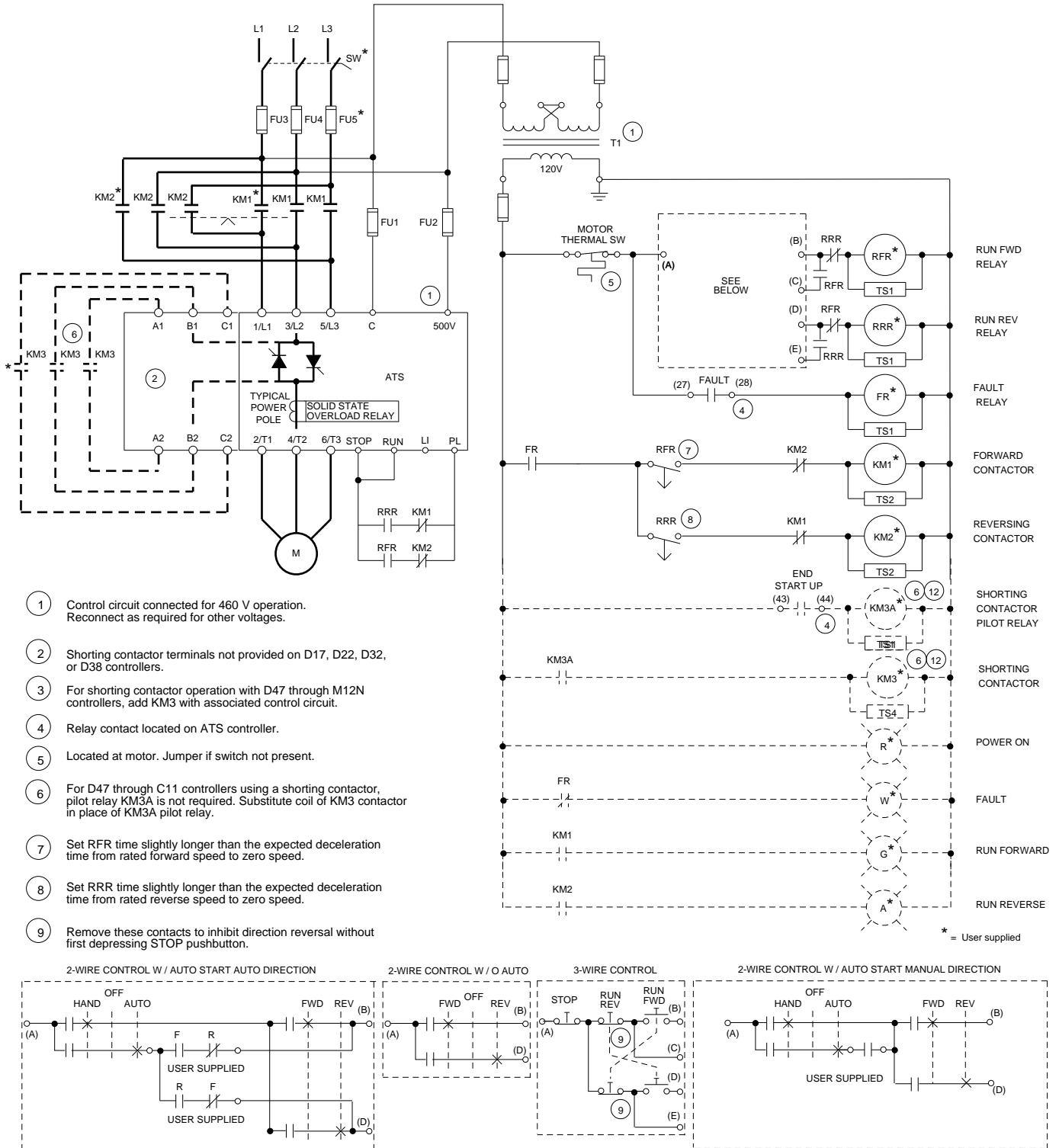


Figure 22: Reversing with Isolation Contactors

**Table 10: Description of Logic for Recommended Circuit Diagrams**

Item	Name	Description
KM1 KM1A	Isolation Contactor (Forward)	The isolation contactor logic closes KM1 upon a start command and opens KM1 after the stop is complete. The RCR (or RFR and RRR for reversing) are timed contacts that must have a time delay greater than the deceleration ramp time or the dynamic braking time. When a coast stop is selected, the time delay must be set for a time that will allow a complete decay of the motor residual voltage. The isolation contactor will open immediately upon a fault. The pilot relay (KM1A) is required when the KM1 contactor coil exceeds the relay rating.
KM2 KM2A	Isolation Contactor (Reverse)	Used for reversing applications only, the KM2 must be mechanically interlocked to KM1. A reversing contactor may be used for the combination of KM1 and KM2. In general, the operation of KM2 is identical to KM1. The pilot relay (KM1A) is required when the KM1 contactor coil exceeds the relay rating.
KM3 KM3A	Shorting Contactor & Pilot Relay	The shorting contactor is used to reduce the heat dissipated by the controller when the motor is operating at full speed and voltage. The starter provides proper sequencing of this contactor by the "end-start-up" relay. When the start is completed, the shorting contactor will be commanded to close. The starter will continue to monitor the motor thermal state and provide motor overload protection. Upon a stop command, the KM3 contactor will open, transferring the motor current to the SCRs to allow for controlled deceleration if desired. The pilot relay (KM3A) is required when the KM3 contactor coil exceeds the relay rating. Refer to Figure 16 on page 20.
TS	Transient Suppressors	Transient suppression of all relay and contactor coils (except ST) is recommended to minimize the possibility of electrical interference with the starter electronics and to increase relay contact life.
RCR	Run Command Relay	Used in all non-reversing logic (optional in shunt trip) for proper sequencing of contactor logic. When energized, RCR initiates the start sequence. When de-energized, stopping is initiated. Operator controls can be either on/off selector switch, HOA selector switch or start/stop push buttons. RCR remains energized during a fault. Once the fault condition has been cleared, RCR must be de-energized by a "stop" command then re-energized to restart the controller.
RFR	Run Forward Relay	Used for reversing applications only, this coil duplicates the functionality of RCR for the forward direction and is interlocked with the RFR relay.
RRR	Run Reverse Relay	Used for reversing applications only, this coil duplicates the functionality of RCR for the reverse direction and is interlocked with the RRR relay.
ST	Shunt Trip Coil	This coil is attached to the shunt trip coil on the disconnect and will energize 2 seconds after a starter fault by the TR timer contact. The time delay is to prevent nuisance tripping of the circuit breaker during controller power-up or during line undervoltage conditions.
TR	Trip Relay	Used in shunt trip circuit breaker logic only; coil energized upon a starter fault.
FR	Fault Relay	Used with logic diagrams that use an isolation contactor. The fault relay is energized during normal operation and de-energizes if the starter fault contacts open or if the motor thermal switch (if supplied) opens. FR also provides additional contacts for the starter fault output.
GFR	Ground Fault Relay	Current-sensitive relay for detection of ground current. If relay is energized, operation of the controller is interrupted by placing in series with the run control relay.

Table 11: Recommended Component List

Induction Motor			ALTISTART Controller				
M			ATS		FU1/FU2		
Rated HP <sup>[1]</sup>			ATS46	Rated Current	ATS Control	Class CC Control Fuse Size	
208V	230V	460V	Model	@ 40C <sup>[2]</sup>	Power Burden	@ 208/230V	@ 460V
3	5	10	ATS46 D17N	17	20VA	1/4	1/4
5	7.5	15	ATS46 D22N	22	20VA	1/4	1/4
7.5	10	20	ATS46 D32N	32	20VA	1/4	1/4
10		25	ATS46 D38N	38	20VA	1/4	1/4
	15	30	ATS46 D47N	47	20VA	1/4	1/4
15	20	40	ATS46 D62N	62	70VA	1/4	1/4
20	25	50	ATS46 D75N	75	70VA	1/2	1/4
25	30	60	ATS46 D88N	88	70VA	1/2	1/4
30	40	75	ATS46 C11N	110	70VA	1/2	1/4
40	50	100	ATS46 C14N	145	70VA	1/2	1/4
50	60	125	ATS46 C17N	176	250VA	1.6	0.8
60	75	150	ATS46 C21N	210	250VA	1.6	0.8
75	100	200	ATS46 C25N	257	250VA	1.6	0.8
100	125	250	ATS46 C32N	320	250VA	1.6	0.8
125	150	300	ATS46 C41N	410	350VA	1.6	0.8
150		350	ATS46 C48N	480	350VA	1.6	0.8
	200	400	ATS46 C59N	590	350VA	1.6	0.8
200	250	500	ATS46 C66N	660	350VA	1.6	0.8
250	300	600	ATS46 C79N	790	500VA	3.0	1.5
300	400	800	ATS46 M10N	1000	500VA	3.0	1.5
400	450	900	ATS46 M12N	1200	500VA	3.0	1.5

To select control operators (push buttons, pilot lamps, and selector switches), control power transformers, and wire management devices (control and power terminal strips, wire terminations) indicated on the referenced control circuit configurations, refer to the latest editions of the Square D product catalogs.

Notes:

- Motor full load currents through 500 hp @ 460 V and 250 hp @ 230 V are taken from UL508 Table 54.2 (NFPA 70, Table 430-150). Above 500 hp @ 460 V and 250 hp @ 230 V, motor full load currents are calculated based upon 1.2 A/hp for 460 V and 2.4 A/hp for 230 V. Motors listed are for standard duty applications. For heavy duty applications, select the next larger controller size.
- The ambient temperature indicated in the table represents the temperature of the air surrounding the ALTISTART controller. Any additional temperature factors associated with the enclosure system or actual installation ambient temperature must be considered when determining the actual rated current ( $I_{CL}$ ) of the starter. For operating ambients above 40 °C but not exceeding 60 °C, the rated current ( $I_{CL}$ ) of the starter must be de-rated by 1.2% per °C.
- All coils are selected for 120 V, 60 Hz operation. Refer to the Digest for additional coil voltages or auxiliary contact configurations. One block may be added to each contactor.
- The fuses listed in the Table 11 provide Type 1 protection to the starter and auxiliary power equipment when the power source short circuit current capability is less than or equal to the values listed in Appendix A.
- Fuse holders listed are for Class R fuses only. Fuse blocks recommended for use with ATS46 models D88 through C48 are Bussmann part numbers. Class L fuses require bolt-on connections to user-supplied power bus work.
- The molded case switches selected require the addition of operator mechanisms to allow operation from the exterior of an enclosure. Refer to the latest editions of the Square D product catalogs for operator mechanism information. When using a shunt trip relay for SCR fault isolation, order a molded case switch with suffix -1021 for addition of shunt trip coil.



for Circuit Diagrams

Contactors [3, 7, 10, 12]				Disconnect [11]		
KM1 Isolation Contactor	KM2		KM3 Shorting Contactor	Fusible Disconnect		
	Reversing Contactor (8)	Mechanical Interlock		Power Fuses Class/Rating (4)	Fuse Block (5)	Molded Case Switch (6)
LC1 D1211G6	LC1 D1211G6	(9)	N/A	RK5 / 20	9080 FB3611R	FHL36000M
LC1 D1811G6	LC1 D1811G6	(9)	N/A	RK5 / 30	9080 FB3611R	FHL36000M
LC1 D3211G6	LC1 D3211G6	(9)	N/A	RK5 / 40	9080 FB3621R	FHL36000M
LC1 D3211G6	LC1 D3211G6	(9)	N/A	RK5 / 45	9080 FB3621R	FHL36000M
LC1 D4011G6	LC1 D4011G6	(9)	LC1 D4011G6	RK5 / 60	9080 FB3621R	FHL36000M
LC1 D5011G6	LC1 D5011G6	(9)	LC1 D5011G6	RK5 / 70	9080 FB3631R	FHL36000M
LC1 D6511G6	LC1 D6511G6	(9)	LC1 D6511G6	RK5 / 90	9080 FB3631R	FHL36000M
LC1 D8011G6	LC1 D8011G6	(9)	LC1 D8011G6	RK5 / 110	6R200A3BE	FHL36000M
LC1 D8011G6	LC1 D8011G6	(9)	LC1 D8011G6	RK5 / 150	6R200A3BE	KHL36000M
LC1 F150G6	LC1 F150G6	LA9 FF970	LC1 F150G6	RK5 / 175	6R200A3BE	KHL36000M
LC1 F150G6	LC1 F150G6	LA9 FF970	LC1 F150G6	RK5 / 200	6R200A3BE	KHL36000M
LC1 F185G6	LC1 F185G6	LA9 FG970	LC1 F185G6	RK5 / 250	6R400A3B	KHL36000M
LC1 F265G7	LC1 F265G7	LA9 FJ970	LC1 F265G7	RK5 / 350	6R400A3B	LHL36000M
LC1 F330G7	LC1 F330G7	LA9 FJ970	LC1 F330G7	RK5 / 400	6R400A3B	LHL36000M
LC1 F400F7	LC1 F400F7	LA9 FJ970	LC1 F400F7	RK5 / 500	6R600A3B	LHL36000M
LC1 F400F7	LC1 F400F7	LA9 FJ970	LC1 F400F7	RK5 / 600	6R600A3B	MHL360006M
LC1 F500F7	LC1 F500F7	LA9 FJ970	LC1 F500F7	L / 650	(5)	MHL360008M
LC1 F500F7	LC1 F500F7	LA9 FJ970	LC1 F500F7	L / 800	(5)	MHL360008M
LC1 F630F7	LC1 F630F7	LA9 FL970	LC1 F630F7	L / 1000	(5)	MHL36000M
LC1 F630F7	LC1 F630F7	LA9 FL970	LC1 F630F7	L / 1200	(5)	MHL36000M
LC1 F780F7	LC1 F780F7	LA9 FX970	LC1 F780F7	L / 1600	(5)	NCL3600012M

Notes: (continued)

7. Power terminals are not included with LC1-F or LC1-B contactors. Refer to the latest editions of the Square D product catalogs for additional ordering information.
8. Reversing contactors for C15 through M12 controllers must be assembled from components. Parts quantities for a basic contactor assembly, minus the power connection links and terminals, are indicated before each part number. Refer to the latest editions of the Square D product catalogs for power connector link and terminal kits. Reversing contactor interlock units used for the C82 through M12 controllers are designed for vertical interlocking of the individual contactors. Horizontally interlocked contactors are used for U70 through C58 controllers.
9. The "D" Line Contactor is available as a reversing configuration. For these applications, change the KM1 part number prefix from LC1- to LC2- to order the KM1 and KM2 combination complete with mechanical interlocks.
10. The use of transient suppressors across all contactor coils is recommended. Refer to the latest editions of the Square D product catalogs for selection of transient suppressors.
11. According to the National Electric Code, branch circuit overcurrent protection must be provided for each controller. Short circuit protective devices recommended in this table are within NEC requirements. Refer to Appendix A for maximum protective device ratings.
12. Contactors are sized for AC1 duty and coordinated for short circuit withstand capability when using the overcurrent protective device recommended in the appendix.



**CHAPTER 3—APPLICATION  
AND PROTECTION**

SOFT START APPLICATION . . . . .	30
Standard Duty Applications . . . . .	30
Heavy Duty Applications . . . . .	30
Reduced Torque . . . . .	30
MODES OF STARTING . . . . .	31
Acceleration Ramp . . . . .	31
Torque Limit . . . . .	32
Current Limit . . . . .	32
Voltage Boost . . . . .	32
MODES OF STOPPING . . . . .	32
Deceleration Ramp . . . . .	32
InTele Braking . . . . .	33
MOTOR PROTECTION AND DIAGNOSTICS . . . . .	33
Thermal Overload Protection . . . . .	33
Excessive Cycling Prevention . . . . .	36
Stall and Steady State Protection . . . . .	37
Protection from Line Faults . . . . .	38
CONTROLLER I/O CONFIGURATION . . . . .	38
Faults/ISO Contactor Control Relays . . . . .	38
End of Start-Up Relay . . . . .	38
Logic Output . . . . .	38
Analog Output . . . . .	39
Logic Input . . . . .	39
DISPLAY OF MOTOR VALUES . . . . .	39

**SOFT START APPLICATION**

The key to applying a soft start successfully is matching the load to the motor capability while starting with reduced voltage applied. The ALTISTART 46 is factory preset to start the motor for which the controller is rated for standard duty applications. A switch is located behind the removable keypad that can be toggled from standard duty to heavy duty application presets.

**Standard Duty Applications**

For standard duty applications, the ALTISTART controller is preset for Class 10 overload protection, a 300% current limit and 10 second acceleration ramp. Typical standard duty applications include most fans and centrifugal pumps. Other standard duty applications include machines such as screw type compressors or conveyors that are started with light or no load.

At the standard duty default settings, 10 starts per hour may be achieved for a maximum of 23 seconds per start without tripping. The standard duty horsepower rating of the controller is listed on the device nameplate. Applications requiring long start times, high starting torque, or frequent starting and stopping may require de-rating of the controller or the use of a shorting contactor to bypass the controller once the motor is up to speed.

**Heavy Duty Applications**

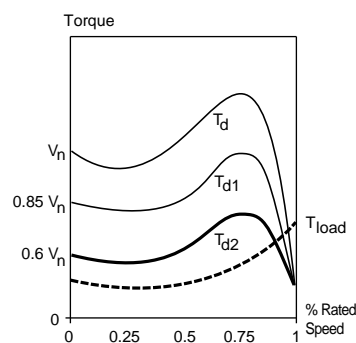
For heavy duty applications, the ALTISTART controller is preset for Class 20 overload protection, a 350% current limit and 15 second acceleration ramp. Heavy duty applications include high inertia loads or other loads requiring long acceleration times. Some examples of heavy duty applications include grinders, crushers, and presses as well as high inertia fans and saws.

For heavy duty applications, the controller must be de-rated by one size. When the duty selector switch is toggled to heavy duty mode, the default motor current setting is adjusted to the rated current of the next lower common motor size. At the heavy duty default settings, 5 starts per hour may be achieved for a maximum of 46 seconds per start without tripping.

If a shorting contactor is used to bypass the SCRs after starting, the controller may be used for heavy duty applications at its standard duty rating. Refer to chapter 3 for additional information regarding the factory presets.

**Reduced Torque**

The asynchronous motor associated with the ATS46 controller must be able to accelerate the driven load when supplied with reduced voltage and current. When reduced voltage is applied to a motor during acceleration, the current the motor will draw is reduced by the ratio of the voltage applied. The torque produced by a motor varies with the square of the voltage at a fixed frequency. The resultant torque produced by a motor then varies with the square of the voltage at a fixed frequency. Figure 23 shows the speed/torque characteristics as a function of the supply voltage.

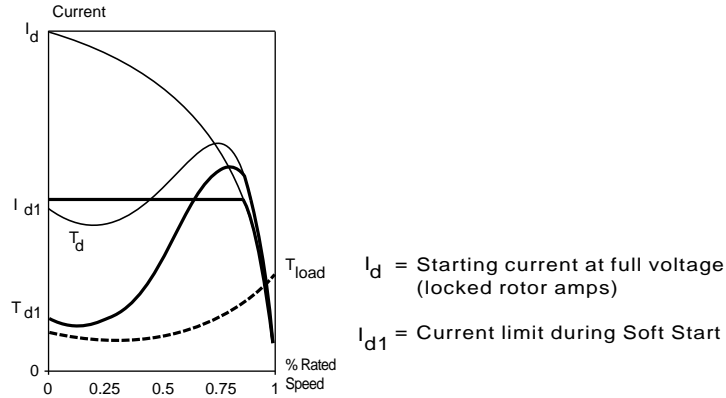


$$T_{d1} \cong T_d \left( \frac{V_n}{V_r} \right)^2$$

$T_d$  = Torque developed at full voltage  
 $T_{d1}$  = Torque developed with reduced voltage  
 $V_n$  = Nominal voltage  
 $V_r$  = Reduced voltage

**Figure 23: Torque as a Function of Applied Voltage**

A “soft start” progressively increases voltage to the motor. By ramping the voltage, the ATS46 controller limits the amount of current the motor can draw during starting to a user-defined setting. Figure 24 shows the speed/torque characteristics of a motor as a function of starting current. The ATS46 controller provides optimal acceleration by ramping the acceleration torque within the envelope of curve  $T_{d1}$ .



**Figure 24: Torque as a Function of Starting Current**

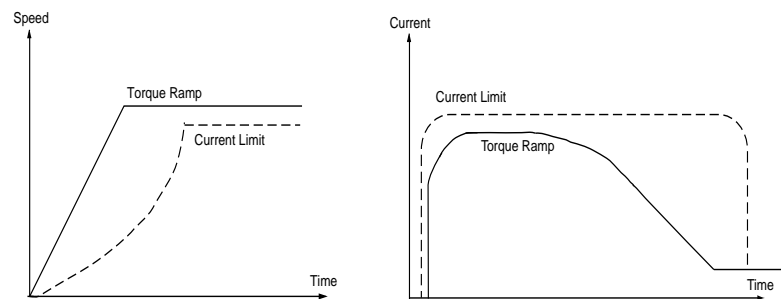
## MODES OF STARTING

The ATS46 controller is factory preset for simple, out-of-the-box operation in many applications. The factory preset provides a 10-second acceleration ramp with 300% of the factory preset nominal current.

### Acceleration Ramp

TCS™ (Torque Control System) ramp is the most widely used acceleration ramp. It is ideal for applications that require a smooth, stepless start. The ATS46 controller uses patented technology to calculate the motor torque continuously. Basing the TCS ramp on the motor torque provides constant acceleration torque ideally suited for most fans, centrifugal pumps, or other variable torque loads.

A torque ramp provides a higher level of control than is available with typical voltage ramping or current limiting soft starters. As shown in the diagrams below, torque ramping compared to a current limited start can provide a more linear speed ramp, reduces the surge of acceleration typical for most soft starts and minimizes the motor temperature rise by reducing the amount of current drawn during acceleration.

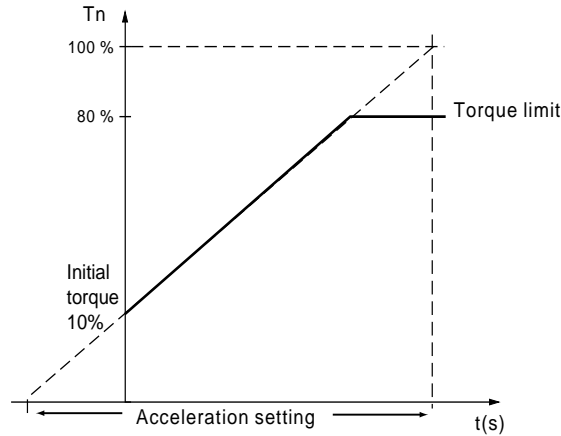


**Figure 25: Torque Ramp vs. Current Limit Starting**

The torque ramp time, or the time to increase from zero torque to the nominal torque of the motor, may be adjusted from 1 to 60 seconds. The initial torque applied is preset for 10% of the motor nominal torque, but may be adjusted from 0 to 100% for maximum flexibility and adaptability for varying loads.

### Torque Limit

As Figure 26 illustrates, the maximum motor torque may be limited to between 10 and 100% of the motor nominal torque. This feature is primarily used to limit acceleration of high inertia or constant torque applications. If used, the torque limit combines with the acceleration ramp and initial torque settings to provide a highly customized acceleration torque profile.



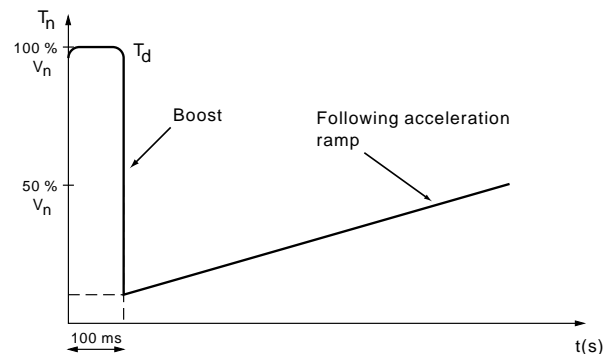
**Figure 26: Acceleration with Torque Limit**

### Current Limit

Current limit starting is used primarily in high-horsepower applications of limited system capacity. The current limit is adjustable from 150 to 500% of the controller current rating. The current limit setting is always active during start up and overrides all other settings. When the user-defined current limit setting is reached, the torque ramp adjusts to prevent excess current draw.

### Voltage Boost

When starting, if the torque is too low due to dry friction, stiff mechanism, or high inertia, the boost function allows the motor to develop increased torque to initiate motor shaft rotation. As Figure 27 shows, the voltage applied during the boost may be adjusted from 50 to 100% of the motor nominal voltage and is applied for 5 cycles of mains power.



**Figure 27: Boost Function**

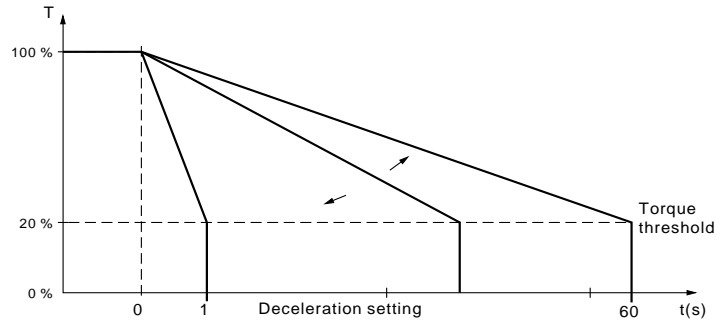
## MODES OF STOPPING

The ATS46 controller can be set for freewheel stop, deceleration ramp, or dynamic braking. The default setting is freewheel stop, which removes all voltage from the motor terminals after a stop command. The time the motor takes to coast to rest depends on inertia and resistive torque of the driven load.

### Deceleration Ramp

Deceleration ramping uses the same principles of the acceleration ramp, providing a gradual deceleration. This feature is typically used in pumping applications to prevent hydraulic shocks or water hammer, which may occur if the motor decelerates too quickly. As shown in Figure 28 on page 33, when deceleration ramping is selected, the ramp time may be adjusted from 1 to 60 seconds. The torque threshold at which the ramp ends may also be adjusted from 0 to 100% of nominal torque.

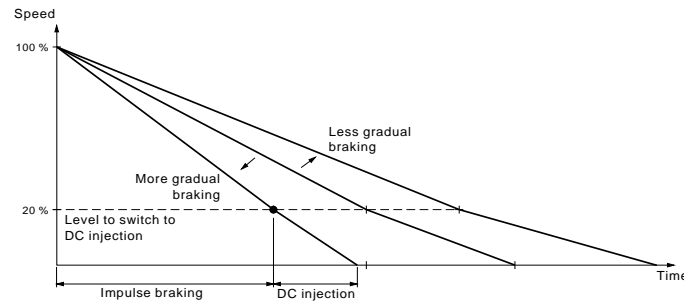
Once the torque reaches the threshold value, the controller changes to freewheel mode and the motor coasts to a stop. The threshold setting is useful in pumping applications, which do not require continued deceleration control once the check valve has closed. If the torque is below the threshold setting at a given stop command, controlled deceleration is not activated and the controller changes to freewheel stop.



**Figure 28: Torque Ramp During Deceleration**

**InTele™ Braking**

InTele Braking is available for applications that require faster than freewheel deceleration time. Impulse braking decelerates the motor to 20% of the rated speed; DC Injection completes the deceleration. The braking level may be adjusted from 0 to 100% to provide gradual ramp. To customize the deceleration ramp, adjust the duration of the DC injection from 20 to 100% of the impulse braking time. If InTele Braking is selected, the controller is preset for 50% braking torque level with a change to DC injection at 20% speed for 20% duration.



**Figure 29: InTele Braking**

**MOTOR PROTECTION AND DIAGNOSTICS**

The ATS46 controller provides state-of-the-art motor protection. On controllers rated 47 A and higher, motor protective features are available even if a shorting contactor is used to bypass the SCRs after the motor is up to speed. To assist with troubleshooting, the 3-digit LCD displays fault status codes. The controller memory registers and maintains the previous 5 faults, even following power loss.

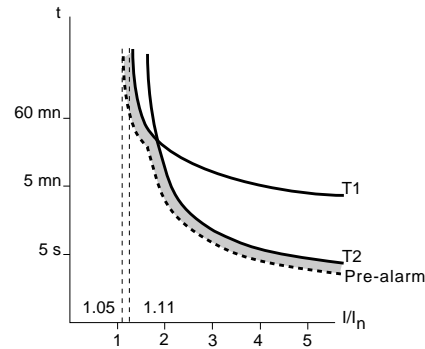
**Thermal Overload Protection**

The ATS46 controller is a UL Listed motor controller with integrated motor and controller thermal protection. The motor and controller temperature are continuously calculated based on the controller nominal current and the current that is actually drawn. An electronic circuit, which stores the thermal state of the motor even if the supply power is disconnected, simulates the cooling curve.

Overload of any kind over any duration can cause the motor temperature to rise. As Figure 30 shows, the ATS46 controller creates a digital model of the motor temperature based on two thermal images. The first (T1) represents the level of temperature rise corresponding to “iron” (motor frame). The second (T2) represents the temperature rise of “copper” (stator, windings). For each thermal image, two levels of alarm are detected.

An overload pre-alarm is signaled by logic output LO1 when the motor has exceeded its nominal temperature rise threshold. A pre-alarm is signaled when the thermal state exceeds 105% for T1 and/or 130% for T2.

A thermal fault signal stops the motor when the temperature rise exceeds the critical threshold. A thermal fault is signaled by relay R1 when the motor thermal state exceeds 110% for T1 and 140% for T2.

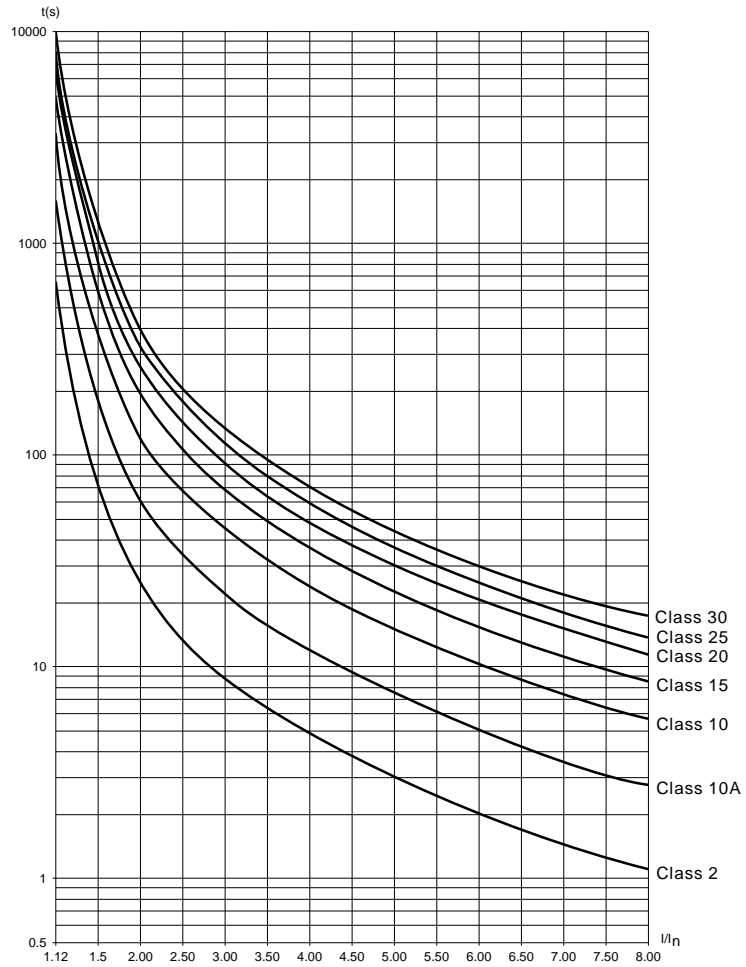


**Figure 30: Thermal Trip Curves**

The ATS46 controller is preset to provide Class 10 overload protection for standard duty applications. The ATS46 controller can be adjusted to provide Class 2, 10A, 10, 15, 20, 25, or 30 overload protection, as necessary. Class 2 protection is available for applications such as submersible pumps, where very tight control of motor temperature is required. Class 30 protection is available for applications such as high inertia loading, where a longer than normal starting time is required to accelerate the load to full speed. In addition, the internal overload protection may be disabled if motor protection is provided externally.

The various thermal overload protection classes are defined to meet the standards of IEC 947-4-2 for starting from both cold and hot states. Starting from a cold state is defined as the stabilized motor thermal state when the motor is off. Figure 31 shows the approximate trip times for starting from a cold state.





**Figure 31: Cold Start Curves**

Starting from a hot state is defined as the stabilized motor thermal state when the motor has been running at full load capacity. Figure 32 on page 36 shows the approximate trip times for starting from a hot state.

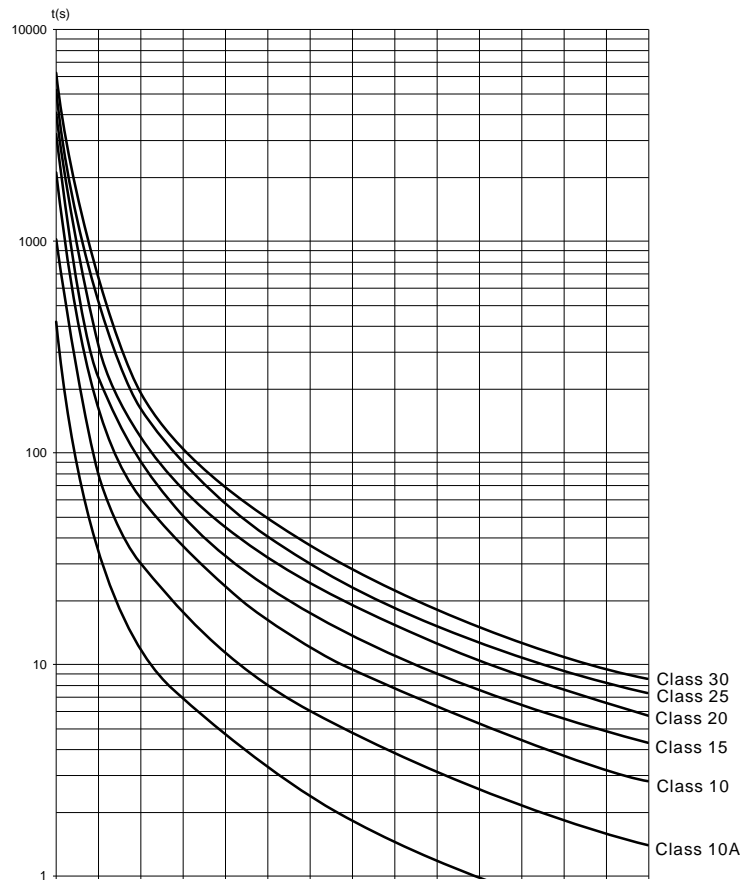


Figure 32: Hot Start Curves

**Excessive Cycling Prevention**

To avoid excessive starting and stopping, adjust the time before starting. The range of adjustment is between 0 and 999 seconds. When using a freewheel stop, the ATS46 controller will not accept a new start command during the time after a STOP command is issued and before the motor starts. When using controlled deceleration, a new START command will not be accepted until: the time elapses after the soft stop; or InTeleBraking is complete. The factory preset of two seconds ensures de-magnetization is complete before motor restart.

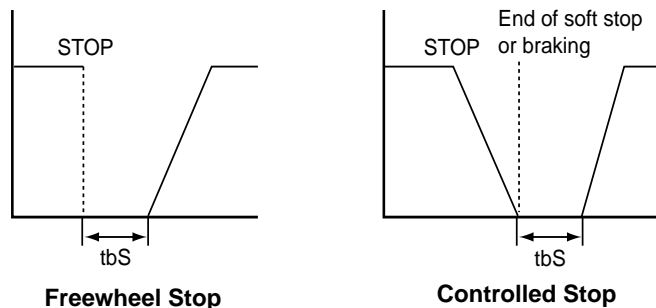
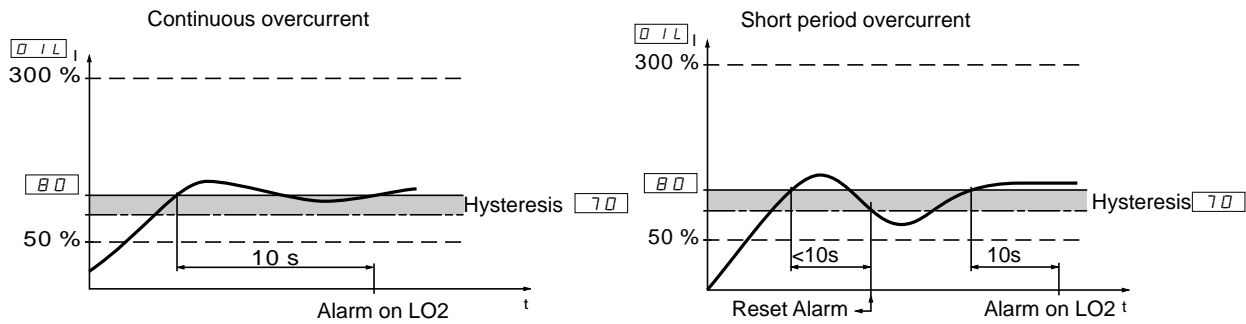


Figure 33: Time before starting

**Stall and Steady State Protection**

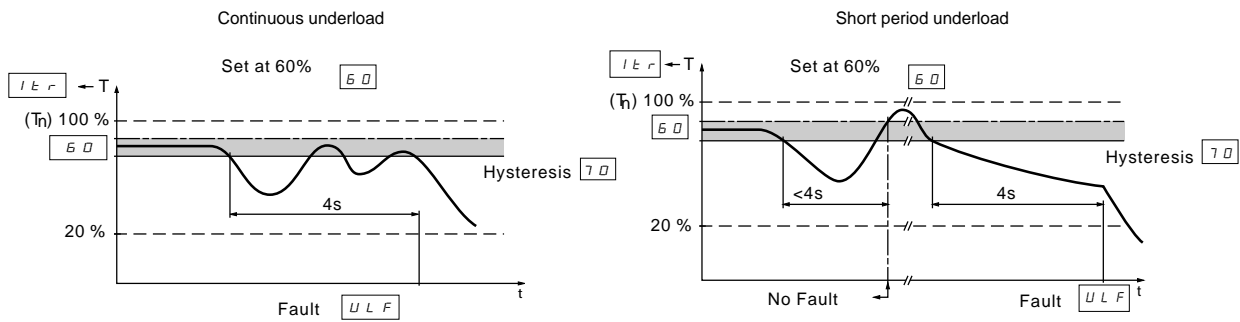
During steady state operation, the ATS46 controller provides protection from stalling during acceleration and jamming, overcurrent, or underload conditions.

- To prevent stalling, set the the maximum start time. It ranges from 10 to 999 seconds. If the time to reach full speed exceeds the stall time, a fault is detected and the start is aborted.
- To protect against jamming after the motor is up to speed, the ATS46 controller detects a fault and aborts motor operation when the current exceeds 5 times the motor rated current for more than 200 ms. This feature is only active when the shorting contactor is used to bypass the controller during steady state operation.
- The current trip threshold may be adjusted from 50 to 300% of the nominal motor current for additional protection during steady state operation. See Figure 34. If an overcurrent condition exists for more than 10 seconds, an alarm is signalled through logic output LO2. Brief overcurrent conditions are allowed without nuisance tripping if the current decreases to a level 10% or more below the overcurrent limit within 10 seconds.



**Figure 34: Current Trip Threshold**

- To protect against underload conditions during steady state operation, the underload limit may be adjusted from 20 to 100% of the motor load state. See Figure 35. An underload fault is detected after 4 seconds of operation below the user-defined level. Brief underload conditions are allowed without nuisance tripping if the loading returns to a level 10% or more above the underload limit within 4 seconds.



**Figure 35: Motor Load Limit Examples**

## Protection from Line Faults

The ATS46 controller provides protection from line faults while allowing for continued operation when supplied with typical industrial power that may contain minor disturbances. The ATS46 controller interrupts motor operation if the following fault conditions are detected:

- Mains supply failure greater than 500 ms.
- Loss of motor phase or shorting contactor connection.
- Supply frequency outside limits upon initialization. For 60 Hz operation, the supply frequency must be between 56.4 and 63.6 Hz. For 50 Hz operation, the supply frequency must be between 47 and 52.5 Hz.

Phase reversal may be selected to prevent operation if the supply phase rotation does not correspond to the specified rotation direction.

The ATS46 controller also trips on overcurrent due to a short circuit at the controller, a shorted SCR, or a shorting contactor malfunction. Although the controller may detect these faults, the user must install an external means of automatically disconnecting the motor from the line supply. This external disconnect provides protection for the motor, driven machinery, and operating personnel.

## CONTROLLER I/O CONFIGURATION

The ATS46 controller provides several inputs and outputs that can be adapted to a variety of functions. The controller is preset at the factory to meet the requirements of most applications. The functions of the inputs, outputs, and optional configurations are described below.

### Faults/Iso Contactor Control Relays

One normally opened and one normally closed contact is supplied for indication of fault or control of an isolation contactor. In the default mode, R1 contacts change state if a fault is detected. The contacts are in their normal state upon application of control power. Once the self diagnostic check is completed, if no fault is found, the fault relay energizes. The fault contacts will change to their de-energized state if a fault condition is detected, or if control power is lost.

If configured for control of an isolation contactor, the R1 contacts stay in their normal state until a run command is initiated. The R1 contacts then stay energized until a fault condition is detected or until deceleration is complete. This allows the user to coordinate an isolation contactor to disconnect the motor from the line under a fault condition or when the motor is not in use.

### End of Start-up Relay

A normally open relay is provided to allow for easy integration of a shorting contactor. The end of start-up relay closes once the motor has reached full speed and opens following a fault condition or after a stop command is initiated. Following a stop command, the end of start-up contact is used to drop out the shorting contactor so that deceleration control may be used if selected.

If a shorting contactor is going to be used to bypass the SCRs after starting is complete, the shorting contactor must close within 500 msec of detection of full speed operation. If a shorting contactor is used, the end of start-up relay must be used to coordinate operation of the shorting contactor.

### Logic Output

Two logic outputs compatible with PLC inputs are provided on the ATS46 controller. The factory preset for LO1 indicates a thermal pre-alarm. In this configuration, the logic output changes to state 1 when a motor thermal overload pre-alarm has been reached, and stays high until the thermal fault has cleared. When a pre-alarm condition exists, corrections should be made to the process to prevent an actual overload fault condition, which requires down time for motor cooling.

The LO1 output may also be configured for motor power indication. In this configuration, the output changes to state 1 whenever the motor current is present.

A second logic output, LO2, is provided to signal an overcurrent alarm. If overcurrent detection is not selected, LO2 is inactive.

**Analog Output**

An analog output is provided that indicates motor status. The A1 output can be configured for 0-20 mA or 4-20 mA output. The analog output is factory preset to indicate motor current, but may be configured to indicate motor torque, thermal state, or power factor.

**Logic Input**

The logic input is factory pre-set to force the controller to a freewheel stop. Alternate configurations include external fault, force to local control, control of cascading motors, and thermal overload reset.

- Force to Freewheel: Overrides controlled deceleration if selected.
- External Fault: Interrupts controller operation following an input from an external fault detection device.
- Local Control: If using the communications option (VW3-G46301), the logic input must be configured for local control. When configured for local control, activating the logic input is required to switch from remote to local operation.
- Control of Cascading Motors: When initiated, allows for control of several motors.
- Thermal Overload Reset: The logic input may be configured to require operator acknowledgment of a thermal overload condition. In this configuration, the logic input must be changed to state 1 after the thermal fault has cleared before the motor may be re-started.
- Fault Reset: The logic input may also be configured to require operator acknowledgement of all faults. In this configuration, the logic input must be changed to state 1 after a fault has cleared before the motor may be restarted.

**DISPLAY OF MOTOR VALUES**

The ATS46 controller provides a three-digit LCD display that can be set up to display the controller and motor characteristics, as described in Table 12.

**Table 12: LCD Display Descriptions**

LCD Display	Description
Controller Status	Displays a ready, run or fault status.
Motor Current	Displays the motor current, from 0 to 6000 amps. Active during acceleration and steady state.
Motor Load State	Displays the motor torque production, from 0 to 150% of the nominal motor torque.
Active Power	Displays the active power as a percentage of the motor nominal power.
Motor Thermal State	Displays the thermal state of the motor, from 0 to 120% of the motor full load amp setting.
Motor Power Factor	Displays the motor power factor, from 0.1 to 1.



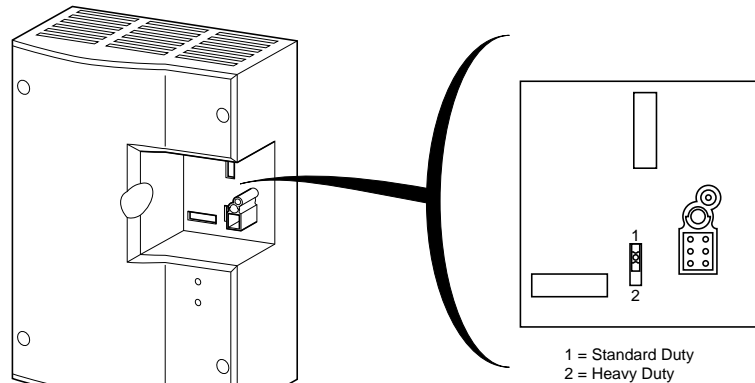
---

**CHAPTER 4—CONTROLLER  
SETUP AND OPERATION**

FACTORY PRESETS . . . . . 40  
USING THE KEYPAD . . . . . 40  
    Selecting a Menu Level . . . . . 41  
    Operating the Pushbuttons . . . . . 42  
ADJUSTING CONTROLLER SETTINGS . . . . . 43  
    Control Parameters . . . . . 43  
    Parameter Flowcharts . . . . . 45  
    Setting the Motor Current . . . . . 51  
    Setting the Current Limit . . . . . 51  
    Advanced Acceleration Ramp Adjustments . . . . . 51

## FACTORY PRESETS

The ALTISTART 46 (ATS46) controller is factory preset, which, for many applications, allows operation without requiring adjustment. As shown in Figure 36, a switch is located behind the removable display module that can be toggled from standard duty to heavy duty application presets.



**Figure 36: Factory Preset Selector Switch**

The ATS46 controller is factory preset to standard duty operation. To switch the factory presets to heavy duty applications, remove the control module and change the selector switch to position 2, as shown in Figure 36 (inset). For the change to take effect, control power must be cycled after adjusting the selector switch. The following factory presets change when adjusting the selector switch from position 1 to position 2:

Parameter		Standard Duty Preset	Heavy Duty Preset
Acceleration Ramp	Ac	10 seconds	15 seconds
Current Limit	lIt	300%	350%
Overload Protection	thp	Class 10	Class 20

Table 20 on page 65 lists the factory preset for the motor nominal current,  $I_n$ , and corresponding motor combinations for standard duty and heavy duty presets. If the motor full load amp rating is not within 95 and 105% of the ATS46 controller factory preset value, or if motor has a 1.0 service factor, adjust the controller for optimal motor protection and performance.

Tables 16 and 17 provide the Level 1, 2, and 3 factory presets for the other parameters available.

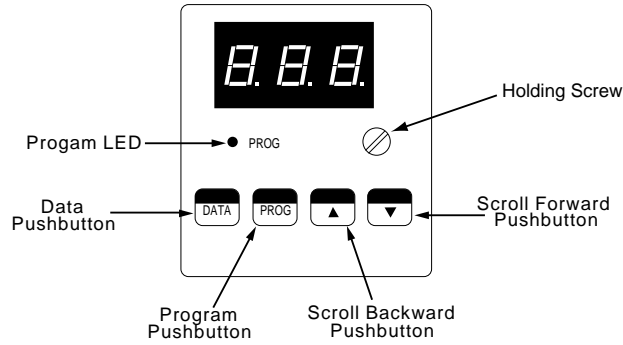
*NOTE: If purchasing a Class 8636, 8638 or 8639 Enclosed ALTISTART, refer to the supplemental instruction bulletin provided. Modifications have been made to the factory settings listed above for some enclosed products to more closely match the motor full load amp ratings at the specified motor voltage. In addition, if an input contactor is provided, the R1 relay has been re-set for isolation contactor control.*

## USING THE KEYPAD

A keypad is provided to allow digital set up of the controller and real-time indication of motor performance. The keypad has three seven-segment display characters, one program LED, and four pushbuttons for programming the controller, as shown in Figure 37.

The keypad may be removed after loosening the holding screw, and can be removed while the controller is switched on. The keypad does not have to be in place in order to operate the controller.

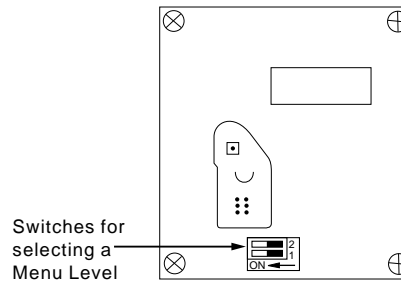




**Figure 37: Front Panel of Keypad**

**Selecting a Menu Level**

The adjustable parameters are separated into three levels. Two switches on the back of the display keypad can be adjusted to provide access to all three programming levels or prevent adjustment to the controller. To avoid accidental controller modifications, the controller is preset: Adjustment cannot occur without first removing the keypad and changing the dip switch setting. Refer to Figure 38.




**Figure 38: Rear Panel of Keypad**





**Table 13: Setup Mode**

Switch Position		When Controller is Ready	When Motor is Running
	<b>Level 1:</b> Basic acceleration and deceleration control parameters.	<ul style="list-style-type: none"> <li>Controller may be started and stopped with presence of run command</li> </ul>	
	<b>Level 2:</b> Includes level 1 parameters and additional set up of more advanced features.	<ul style="list-style-type: none"> <li>Display of monitoring parameters (level 1 &amp; 2 only)</li> <li>Display and modification of adjustment parameters</li> </ul>	<ul style="list-style-type: none"> <li>Display of monitoring parameters</li> <li>Display and modification of adjustment parameters</li> <li>Display of configuration parameters; no modification of configuration parameters</li> </ul>
	<b>Level 3:</b> Reconfiguration of controller operation independent of level 1 and 2 parameters.	<ul style="list-style-type: none"> <li>Display and modification of configuration parameters</li> <li>Display of fault codes</li> <li>Prog LED lit</li> </ul>	

**Table 14: Adjustment Lockout Mode**

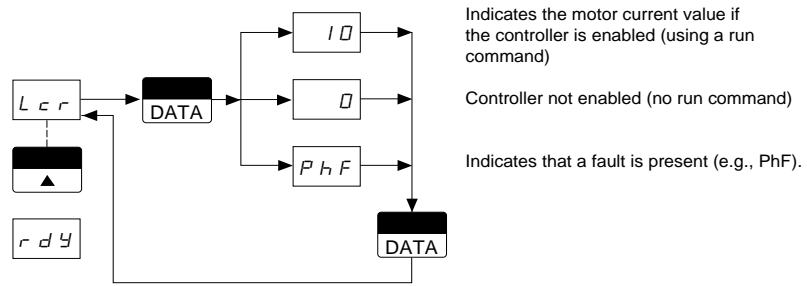
Switch Position	When Controller is Ready or Motor is Running
 <p><b>Level 0:</b> Operating Mode. No adjustment possible.</p>	<ul style="list-style-type: none"> <li>• Controller may be started and stopped with presence of run command</li> <li>• Display monitoring parameters</li> <li>• Display of Level 2 parameters and settings</li> <li>• Display of fault codes</li> <li>• No modifications possible</li> </ul>

**Operating the Pushbuttons**

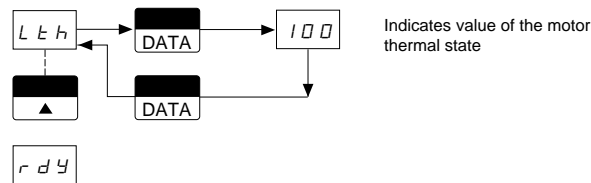
Key	Operation	
	When parameter name is displayed	When parameter value is displayed
	Steps forward through parameter list	Increases parameter value
	Steps backward through parameter list	Decreases parameter value
	Displays parameter value	Displays parameter name or cancels change to parameter value
		Saves change to parameter value

**ADJUSTING CONTROLLER SETTINGS**

At any time, the user may select which parameter is to be displayed. If the motor is idle, the next time the motor is started, the selected motor starting parameter is displayed. If the motor is running while the adjustment is made, the desired monitoring parameter is displayed after pressing the DATA pushbutton.



Monitoring motor current (Lcr) and torque (Ltr)



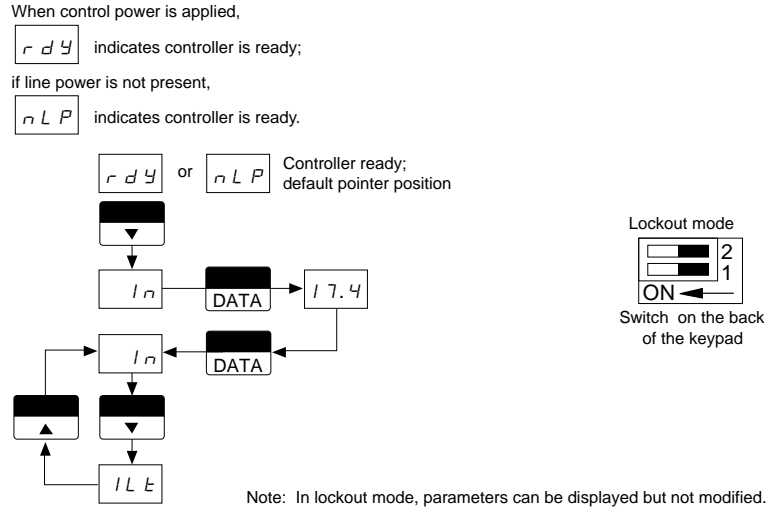
Monitoring motor thermal state (Lth) and power factor (cos)

**Figure 39: Displaying the Monitoring Parameters**

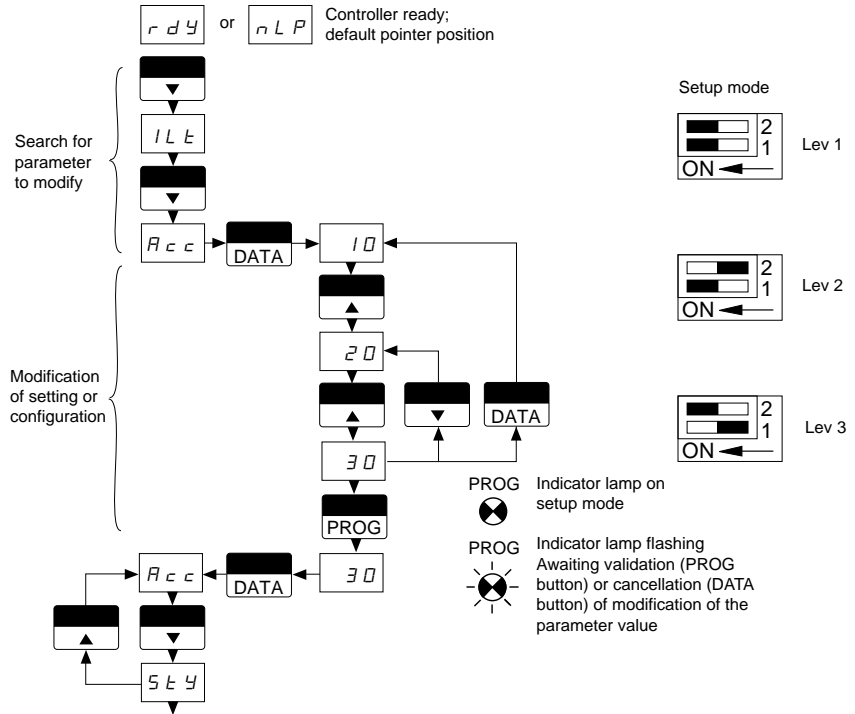
**Control Parameters**

Control parameters consist of configuration and adjustment parameters. Configuration parameters indicate the type of control or on/off selections and can only be modified when the controller is in a ready status. Adjustment parameters are functions that have an adjustment range or level, and can be modified at any time in setup mode.

For example, the type of deceleration control is a configuration parameter and cannot be changed once the motor is operating. However, the deceleration ramp time is an adjustment parameter and may be adjusted at any time in setup mode. If adjusted prior to a stop command, the deceleration time adjusts to the new setting at the next stop command.



**Figure 40: Displaying the Control Parameters While in Lockout Mode**



**Figure 41: Displaying/Modifying the Control Parameters While in Setup Mode**

Parameter Flowcharts

ATS46 controller setup is accomplished using the keypad, as described in "Using the keypad" on page 42. The flowcharts displayed in Figures 42, 43, and 44 list the order in which the parameters appear when scrolling through the menus. Tables 16 and 17 provide the description, adjustment range and factory preset for each parameter.

When control power is first applied, the pointer is on `rdy` or `nLP` for levels 1 and 2.

Pressing **▲** positions the pointer on the `Lcr` parameter.

Pressing **▼** positions the pointer on the `ln` parameter.

- Monitoring parameter
- Adjustment parameter
- Configuration parameter
- Selection of stop type

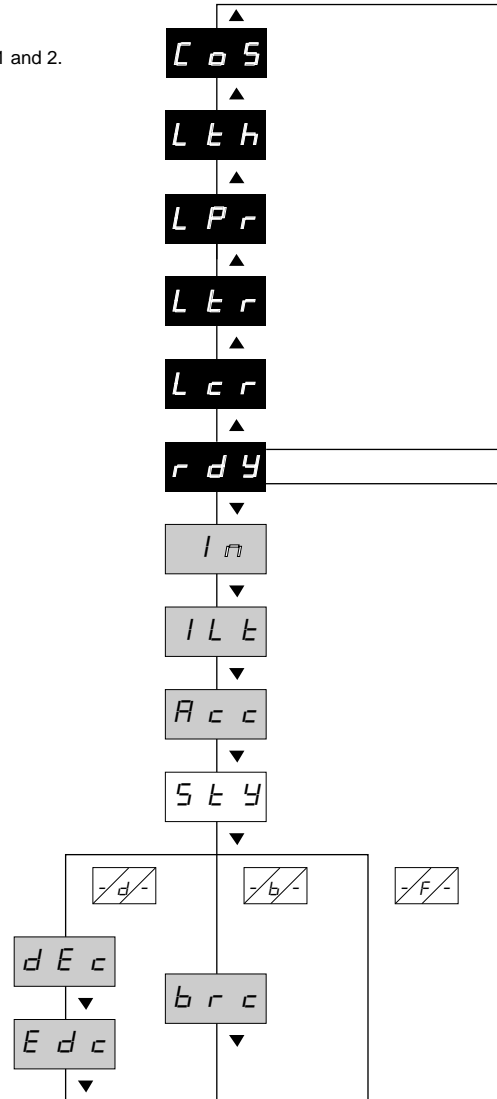


Figure 42: Level 1 Parameters

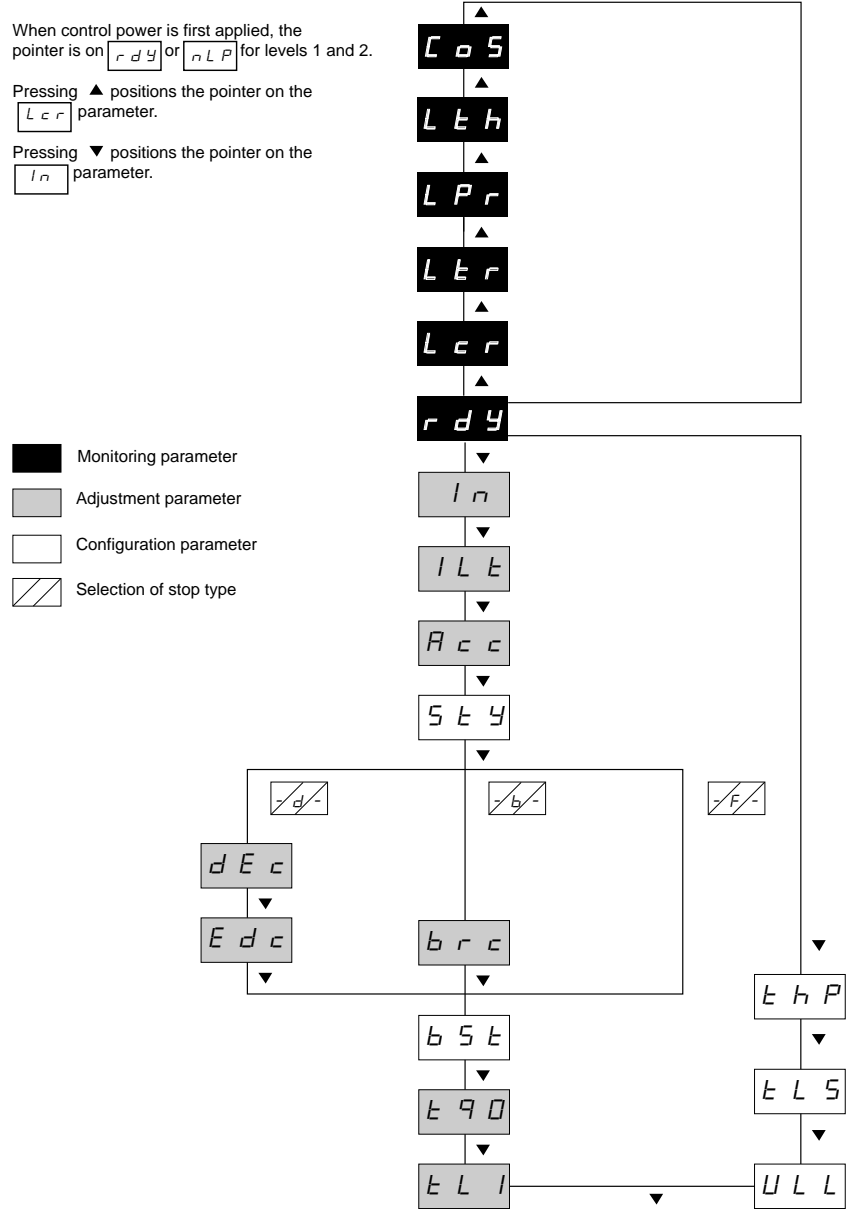


Figure 43: Level 2 Parameters

When control power is first applied, the pointer is on **A r S**

- Monitoring parameter
- Adjustment parameter
- Configuration parameter

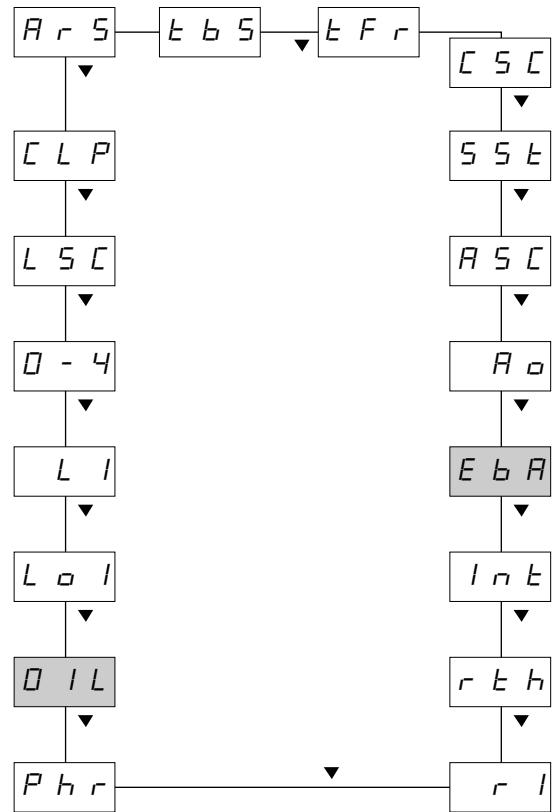


Figure 44: Level 3 Parameters

Table 15: Monitoring Parameters

Monitoring Parameters	Display Range	Description
C o s    Motor power factor	0.1 to 1	If selected, indicates the power factor of the motor while running.
L t h    Motor thermal state	0 to 250%	If selected, the motor thermal state is displayed, expressed as a percentage of the normal operating temperature.
L P r    Active Power	0 to 250% of the nominal motor power	If selected, the active power of the motor during acceleration, deceleration, and steady state operation is displayed. The active power is displayed as a percentage of the motor nominal power.
L t r    Motor load state	0 to 250% of the nominal motor torque	If selected, the motor load state during acceleration, deceleration and steady state operation is displayed. The load state is expressed as a percentage of the motor nominal torque.
L c r    Motor current	0 to 6000 amps	If selected, the motor current during acceleration, deceleration and steady state operation is displayed. If the current is less than 1000 amps, the current is displayed in amps. If the current is greater than 1000 amps, the current is displayed in kiloamps. For example: 1.5 amps is displayed as 1. 5 78.6 amps is displayed as 78. 6 384 amps is displayed as 384 1255 amps is displayed as 1. 25
r d y    Controller status	r d y, r u n or fault status	After control power is applied, the display is blank for a brief period while the controller performs self diagnostics. If all is clear, the r d y or ready controller status is displayed. The display changes to r u n once a start command is given. The r u n display flashes during acceleration, deceleration and braking. During steady state operation, the r u n display is steady. If a fault is incurred during diagnostics or controller operation, the applicable fault code is displayed in place of the controller status display

Table 16: Level 1 and 2 Parameters

Parameter	Type	Display Range	Preset	Description
$I_n$ Nominal motor current (Level 1 or 2)	C	50 to 130% of the controller rated current	See Table 20 on page 65.	The nominal motor current is factory set according to the controller rating and position of the switch beneath the keypad. If the factory setting is not between 95 and 105% of the motor FLA rating, adjust the $I_n$ to obtain optimal performance and thermal protection. See "Setting the Motor Current" on page 52.
$I_{Lk}$ Current Limit (Level 1 or 2)	A	150 to 700% $I_n$ - max 500% $I_{CL}$	300	Sets the maximum current drawn during acceleration. See "Setting the Current Limit" on page 53.
$R_{cc}$ Acceleration torque ramp (Level 1 or 2)	A	1 to 60 seconds	10	Adjusts the acceleration torque ramp. Adjusting the $R_{cc}$ setting changes the slope of the torque reference, providing a more or less gradual start.
$Sty$ Stop type (Level 1 or 2)	C	- F - - d - - b -	- F -	Selects the stopping control method. Selecting - F -, - d - or - b - indicates freewheel, deceleration ramp or braking. In freewheel mode (- F -), all voltage is removed from the motor following a STOP command. The motor coasts to a stop with the deceleration time dictated by the inertia and resistive torque of the driven load.
$dEc$ Deceleration ramp time (Level 1 or 2)	A	1 to 60 seconds	10	If deceleration ramping (- d -) is selected, the user may adjust the ramp time and voltage at which the ramp ends. $dEc$ is used to adjust the time to change from measured torque to zero torque.
$Edc$ Threshold for change to freewheel at end of deceleration (Level 1 or 2)	A	0 to 100% of the measured nominal motor torque	20	If deceleration ramping (- d -) is selected, the torque level at which the deceleration ramp ends may be adjusted. Once the torque reaches the threshold value, the controller changes to freewheel mode and the motor coasts to a stop. If the torque is below the threshold setting when a stop command is given, controlled deceleration is not activated and the controller changes to freewheel stop.
$brc$ Braking torque level (Level 1 or 2)	A	0 to 100%	50	If braking (- b -) is selected, adjusts the braking level used during InTele braking. Note that the duration of the braking application is dependent on the motor loading.
$bSt$ Voltage boost (Level 2 only)	C	50 to 100% of the supply voltage	OFF	If torque is too low on starting due to dry friction, stiff mechanism or high inertia, the boost function provides increased torque to initiate motor shaft rotation. Voltage is applied for 5 mains cycles during boost.
$tq0$ Initial torque on starting (Level 2 only)	A	0 to 100% of measured nominal motor torque	10	Adjusts the initial torque upon energization. The initial torque setting and the slope indicated by the $R_{cc}$ define the motor starting performance. The starting performance may be optimized by adjusting the initial torque setting without modifying the slope of the ramp.
$tLi$ Limitation of maximum torque (Level 2 only)	A	10 to 200 of measured nominal motor torque	OFF	Limits the peak torque provided by the motor. Primarily used to limit acceleration of high inertia applications, the torque limit combines with the slope and initial torque settings to provide a customized torque profile.
$ULL$ Motor underload threshold (Level 2 only)	C	20 to 100 of measured nominal motor torque	OFF	An underload threshold can be set to prevent damage to the driven machinery or process resulting from an underload condition (i.e., dry pump condition). The underload detection is only active during steady state operation. To prevent nuisance tripping, the underload condition must last for 4 seconds. If a short underload condition occurs and loading returns to a value 10% above the user-defined threshold, the underload detection is reset. Detection of continuous and brief underload conditions is shown in Figure 37 on page 43.
$tL5$ Maximum start time (Level 2 only)	C	10 to 999 seconds	OFF	Compares the motor acceleration time to the time set using $tL5$ . If the time is exceeded, the controller changes to a fault state of stF.
$thP$ Motor thermal protection (Level 2 only)	C	OFF to 30	10	The thermal overload class can be adjusted to provide Class 2, 10, 10A, 15, 20, 25 or 30 overload protection as defined per IEC 947-4-2. The thermal overload protection may be turned off if external protection is provided. Refer to Figure 36 on page 42 and Figure 37 on page 43 for information about trip curves for motor starting.

Type Abbreviations: A=Adjustment; C=Configuration



Table 17: Level 3 Parameters

Parameter	Type	Adjustment Range	Preset	Description
<i>A r 5</i> Automatic reset	C	<i>o F F - o n</i>	<i>o F F</i>	Refer to Table 18 on page 57 for automatic reset operation.
<i>L L P</i> Torque control	C	<i>o F F - o n</i>	<i>o n</i>	Torque control should be turned off for applications using motors connected in parallel on the same controller or a motor whose power is very low in relation to the rating of the controller.
<i>L 5 c</i> Stator loss compensation	C	20 to 90%	<i>5 0</i>	<i>L 5 c</i> optimizes the precision of the starting torque for constant torque applications.
<i>0 - 4</i> Configuration of AO1	C	<i>0 2 0 - 4 2 0</i>	<i>0 2 0</i>	Analog output AO1 can be configured to 0 - 20 mA or 4 - 20 mA.
<i>L I</i> Assignment of LI	C	<i>o F F - L I R</i> <i>L I E - L I H - L I L</i> <i>L I C - L I I - L I t</i> <i>L I r</i>	<i>L I R</i>	The following settings are available for assigning logic input LI: <i>0 F F</i> = not assigned <i>L I R</i> = freewheel stop <i>L I E</i> = external fault <i>L I H</i> = reserved <i>L I L</i> = local control <i>L I C</i> = control of cascading motors <i>L I I</i> = reserved <i>L I t</i> = motor overload reset <i>L I r</i> = fault reset
<i>L o 1</i> Assignment of LO1	C	<i>o F F - t R 1 n n 1</i>	<i>t R 1</i>	The following settings are available for assigning logic output LO1: <i>t R 1</i> = motor thermal alarm <i>r n 1</i> = motor powered
<i>0 I L</i> Current trip threshold	A	50 to 300% of $I_n$	<i>o F F</i>	This alarm is only active during steady state operation. An overcurrent condition, in relation to the threshold that has been set, must last 10 seconds to activate alarm LO2.  If a short overcurrent condition occurs and the current returns to a value 10% below the user-defined threshold, the overcurrent detection is reset. Detection of continuous and brief overcurrent conditions is shown in Figure 36 on page 42.
<i>P h r</i> Detection of phase rotation	C	<i>o F F - 1 2 3 3 2 1</i>	<i>o F F</i>	Checks the direction of phase rotation in the mains supply. If the supply does not correspond to the selection, the controller changes to fault state PIF. This function is only activated if a run request is issued.
<i>r 1</i> Assignment of relay R1	C	<i>r I F - r I L</i>	<i>r I F</i>	The following settings are available for assigning relay R1: <i>r I F</i> = fault relay <i>r I L</i> = isolation relay (controls a line contactor)
<i>r t h</i> Reset of motor thermal state	C	<i>n o - 4 E 5</i>	<i>n o</i>	After a request to reset the motor thermal state, parameter <i>r t h</i> returns to no. Using this parameter should be limited to maintenance operations (changing motor, starter, etc.).
<i>I n t</i> Return to factory setting	C	<i>n o - 4 E 5</i>	<i>n o</i>	The <i>i n t</i> parameter automatically returns to the factory setting. After a request to return to factory settings, <i>i n t</i> returns to no.
<i>E b R</i> Adjustment of braking time	C	0 to 100%	<i>2 0</i>	If braking (- b -) is selected, adjusts the motor stop time after the impulse braking phase.
<i>A o</i> Assignment of analog output AO1	C	<i>o F F - A c r</i> <i>A t r - A t h - A C 0</i>	<i>A c r</i>	The following settings are available for assigning analog output AO1: <i>0 F F</i> = not assigned <i>A c r</i> = motor current <i>A t r</i> = motor torque <i>A t h</i> = motor thermal state <i>A C 0</i> = power factor Output can be configured to 0 - 20 mA or 4 - 20 mA using the parameter 0 - 4 and can be scaled using <i>A 5 c</i> .
<i>A 5 c</i> Scaling of analog output AO1	C	<i>5 0 - 5 0 0</i>	<i>2 0 0</i>	Adjusts from 50 to 500% of the selected value; 20 mA corresponds to full scale.

Table 17: Level 3 Parameters (Continued)

Parameter	Type	Adjustment Range	Preset	Description
55L Test on low power motor	C	00 - 0FF	0FF	Checks the controller in a test or maintenance environment without having to use a motor with a motor power rating equivalent to that of the controller (esp. high powered controllers). Torque control (CLP) is automatically disabled when using 55L.
CLC Cascade operation	C	00 - 0FF	0FF	Signals the operation of cascading motors. TCS ramp is inactive in this mode because the motor power does not match the controller rating.
EFr Elapsed time	C	00 - 0FF	0FF	Indicates the operating time, in hours, since the last reset. Elapsed time includes starting, running and stopping time. May only be reset using one of the line communication options: VW3G46104 PC software or VW3G46301 PLC communication.
EB5 Time before starting	C	0 - 999	2	The time after a STOP command in freewheel mode or after the end of ramp or braking before a new START command will be accepted.

Type Abbreviations: A=Adjustment; C=Configuration

### Setting the Motor Current

The motor nominal current ( $I_n$ ) is factory preset to the values listed in Table 16 on page 50. If the preset value is not within 95-105% of the motor nameplate current, or if using a 1.0 service factor motor, the  $I_n$  parameter should be adjusted as follows:

Service Factor	Setting
1.0	$I_n = 0.96 \times \text{Nameplate Current}$
1.15 or 1.25	$I_n = 1.00 \times \text{Nameplate Current}$

For 1.15 or 1.25 service factor motors, the nominal current may be set as high as 104% of the nameplate current if required to prevent nuisance tripping.

## ⚠ CAUTION

### MOTOR OVERHEATING

Motor current draw above nameplate rating will result in motor temperature rise. Extended exposure to overcurrents will cause the motor to overheat resulting in thermal overload fault or equipment damage.

The following conditions can cause excessive heating:

- Excessive duty cycle (more than 6 evenly spaced starts per hour)
- Excessive acceleration ramp due to high inertia loads
- High ambient temperature

Check with the motor manufacturer for the motor's suitability for operation on a solid-state reduced voltage controller configured for your application.

- Motor thermal sensors built into the motor windings and connected through the control logic may be required for motor protection.
- Specific application duty motors, such as explosion proof and submersible motors will require enhanced protection and special considerations in application. The motor manufacturer MUST be consulted when applying these motors.

**Failure to follow this instruction can result in injury or equipment damage.**

### Setting the Current Limit

The current limit is expressed as a percentage of the  $I_n$  setting and is adjustable from 150 to 700%. However, the maximum starting current is limited to 500% of the controller rated current. The peak amperage drawn using the current limit feature can be determined by the following formula:

$$I_{IL} * (I_n / I_{CL}) \leq 500$$

For example, if the motor FLA equals the controller rated amps, the maximum current limit setting would be 500. If using a motor rated for 50% of the controller rating (the minimum setting), the current limit may be set as high as 700%.

### Advanced Acceleration Ramp Adjustments

For constant torque or high performance applications, the performance of the ALTISTART 46 controller may be optimized by the following steps:

1. Measure load requirements:
  - a. Set controller to monitor load torque (LTR).
  - b. Start the motor with the factory default settings.
  - c. Load the motor to the maximum continuous load torque for the application.
  - d. Read the measured torque (LTR) for continuous duty (normal speed).
  - e. Stop the motor.
2. Adjust the controller:
  - a. Set the current limit (ILT) to the maximum setting to provide the maximum starting torque.
  - b. Set the initial torque (tq0) and torque limit (tLI) to 120% of the measured load requirements. For example, if LTR = 50, set tq0 and tLI to 60.
3. Optimize the application:
  - a. Issue a run command. If the motor starts, reduce the stator loss compensation (LSC) by 10. Repeat until the motor no longer starts then increase by 10. The application is then optimized to within 10%.
  - b. If the motor does not start, increase the stator loss compensation (LSC) by 10. Repeat until the motor starts. The application is then optimized to within 10%.



**CHAPTER 5—FAULT  
MANAGEMENT**

INTRODUCTION .....54  
    Fault Relay Setup .....54  
    Fault Display .....54  
RESETTING THE CONTROLLER .....54  
    Fault Definitions.....55  
TROUBLESHOOTING FAULTS.....56  
    Phase Fault.....56  
    Frequency Fault .....56  
    Supply Fault with Run Command Present .....57  
    Motor Thermal Fault .....57  
    Starter Thermal Fault .....57  
    Locked Rotor Fault .....57  
    Motor Underload Fault.....58  
    Max Starting Time Exceeded .....58  
    External Fault .....58  
    Internal Serial Link Fault .....58  
    Overcurrent Fault .....59  
    Internal Failure Fault .....59  
    Phase Inversion Fault .....59

## INTRODUCTION

The ALTISTART 46 (ATS46) controller provides state-of-the-art protection for the motor and controller and provides flexibility and the ability to adapt to normal power disturbances. The following describes the diagnostics available on the ALTISTART 46 controller as well as how the controller will respond to the type of fault detected in manual and automatic restart modes. Finally, conditions which may have caused the fault condition and corrective actions for each fault code are given.

### **⚠ DANGER**

#### **HAZARDOUS VOLTAGE**

Read and understand these procedures before servicing ATS46 controllers. Installation, adjustment, repair, and maintenance of these controllers must be performed by qualified personnel.

**Electrical shock will result in death or serious injury.**

## Fault Relay Setup

The ATS46 controller provides relay and logic output for fault indication. Both fault outputs can be configured to meet application requirements, which can then be set up to provide customized fault indication. The controller can also be set up for automatic restart. Refer to Chapter 3 for details on programming the controller.

Logic output LO1 is factory preset to indicate a motor thermal pre-alarm, which may be configured to initiate a correction in the process prior to exceeding the thermal capacity of the motor. The LO1 logic output may also be configured to signal that the motor is running.

Relay output R1 is configured by the user to provide detection of a fault only or control of an isolation contactor. A normally open and normally closed contact are provided to signal external devices. When in the factory default configuration, the R1 relay will energize following a successful self-diagnostic test and remain energized until a fault condition is detected. The R1 relay is in the de-energized state when control power is not applied and when a fault is detected.

If configured for control of an isolation contactor, the R1 relays stay in the de-energized state until a start command is issued. Following a start command the R1 relays remain energized until deceleration is complete or until a fault is detected. If controlled deceleration is not selected, the R1 relays change state following a stop command. This provides automatic interruption of the line voltage following a fault and when the motor is not in use.

## Fault Display

If a fault occurs during the operation of the ALTISTART controller, a fault code is displayed on the keypad indicating the starter status. The last five faults that have occurred are stored in controller memory. To view the fault memory buffer, use the PC or PLC option. To view the controller settings while a fault code is displayed, press the DATA push-button until the programming menu is displayed. A red LED on the front of the controller also indicates a fault condition.

## RESETTING THE CONTROLLER

Fault conditions are broken into three categories: internal, phase, and thermal. To restart the motor, the fault condition must be cleared and the controller must be reset. The method used to reset the controller depends on the type of fault detected and if automatic re-start is selected.

**Fault Definitions**

The ATS46 controller continuously monitors the motor and starter performance. If a fault is detected, the controller will interrupt motor operation and switch to a freewheel stop. After the fault has cleared, the steps required to restart the motor depend on the type of fault that was detected. The following is a guide for restarting following a fault condition:

**Cycle Control Power:** Cycling control power resets the controller following any fault condition and is required for non-resettable faults. A new or maintained run command will restart the motor after control power is recycled if the fault has cleared.

**Manual Restart:** The controller may be restarted by issuing a new run command after any resettable fault once the fault has cleared.

**Auto Restart:** If selected, the controller will restart automatically only if a maintained run command is preset, when using two wire control. An automatic restart will only occur after specific faults have cleared. Following a Type 1 fault, the controller will restart once the fault has cleared. Following a Type 2 fault, the controller will attempt to restart the motor after 60 seconds. If the fault has not cleared after 6 successive attempts, the fault must then be reset by cycling control power. A manual restart is required following a Type 3 fault.

<b>⚠ WARNING</b>
<p><b>UNINTENDED EQUIPMENT ACTION</b></p> <ul style="list-style-type: none"> <li>• Automatic restart can only be used for machines or installations that present no danger for personnel or equipment in the event of automatic restarting.</li> <li>• Equipment operation must conform with national and local safety regulations.</li> </ul> <p><b>Failure to follow this instruction can result in death or serious injury.</b></p>

**Table 18: Fault Definitions**

Code	Description	Refer to Page	To Restart Motor			Type
			Cycle Control Power	Manual Restart	Auto Restart	
<i>D c F</i>	Overcurrent fault	61				
<i>I n F</i>	Internal failure fault	61	X			
<i>P i F</i>	Phase inversion fault	61				
<i>P h F</i>	Phase fault	58		X	X	1
<i>F r F</i>	Frequency fault	58				
<i>U S F</i>	Supply fault	59		X	X	2
<i>D L F</i> <sup>[1]</sup>	Motor thermal fault	59				
<i>D h F</i>	Starter thermal fault	59				
<i>L r F</i>	Locked rotor fault	59				
<i>U L F</i>	Motor underload	60		X		3
<i>S t F</i>	Max start time exceeded	60				
<i>E t F</i>	External fault	60				
<i>S L F</i>	Serial link fault	60				

[1] If LI is configured for motor overload reset (Lit), operator acknowledgment of the overload condition is required. The overload must also be reset through the logic input after the fault has cleared before restarting the motor.

## TROUBLESHOOTING FAULTS

Resetting the controller once the fault has cleared may not correct the condition that caused the fault to occur. In addition, there are failure modes of this controller which may require an external device to ensure power is removed from the motor. Refer to Chapter 2 for proper installation guidelines.

### **⚠ CAUTION**

#### **MOTOR OVERHEATING**

Failure of the controller solid-state switches can cause single-phase operation of the motor.

- Use an isolation device consisting of either a circuit breaker equipped with a shunt trip coil or an electromagnetic contactor to open the line side of the controller.
- The isolation device must be capable of interrupting motor locked rotor current.
- Connect the Fault relay of the ALTISTART controller to open the isolation device in the event of a controller fault.

**Failure to follow this instruction can result in injury or equipment damage.**

The following guidelines provide general troubleshooting assistance based on the fault code displayed on the keypad. If the controller is still inoperative after checking the motor and system status as recommended, consult your local Square D sales office.

### Phase Fault

Fault Code: *P h F*

Possible Cause:

- Mains supply failure greater than 500 ms when run command is present.
- Motor current draw less than 10% of the nominal starter rating.
- SCR failure
- Power factor greater than 95% lagging

Corrective Action:

- Verify that supply voltage is present on L1-L2-L3 terminals. If an isolation contactor is used, it must close within 200 ms of a run command.
- Check for open phases including:
  - Blown fuses
  - Open or loose power connections
  - SCR failure - not resettable via control logic
- If the fault is detected after completion of the acceleration ramp, ensure that the proper connection of the shorting contactor if used. The output of the shorting contactor must be connected to terminals A2-B2-C2, and must close within 200 msec after the motor is up to speed.
- Motor current draw must be more than 10% of the controller rating while running without a shorting contactor.

### Frequency Fault

Fault Code: *F r F*

Possible Cause:

- Mains supply frequency outside acceptable limits.

Corrective Action:

Check that the frequency is between

- 60 Hz +/- 3.6 Hz (56.4 Hz to 63.6 Hz)
- 50 Hz +/- 2.5 Hz (47.5 Hz to 52.5 Hz)



**Supply Fault with Run Command Present**

Fault Code: *U 5 F*

Possible Cause:

- Voltage is not present at L1-L2-L3 terminals when a run command is present.

Corrective Action:

- Verify that supply voltage is present on L1-L2-L3 terminals. If an isolation contactor is used, it must close within 200 ms of a run command.
- Check for open phases including:
  - Blown fuses
  - Open or loose power connections
  - SCR failure - not resettable via control logic

**Motor Thermal Fault**

Fault Code: *D L F*

Possible Cause:

- Motor overload
- Excessive starting or stopping time or frequency
- Motor operating current incorrectly set

Corrective Action:

- Inspect motor and driven equipment for problems, including:
  - locked shaft
  - mechanical overload
- Check the dynamics of the load and driven machine for suitability with reduced voltage starting.
- Check the duty cycle for the selected thermal overload class.
- Check the  $I_n$  setting.

**Starter Thermal Fault**

Fault Code: *D h F*

Possible Cause:

- Duty cycle above the thermal capabilities of the controller.
- Ambient temperature too high.
- Poor air circulation/lack of ventilation.

Corrective Action:

- Reduce duty cycle demand on controller.
- Provide additional cooling around controller.
- Reduce ambient temperature requirements.

**Locked Rotor Fault**

Fault Code: *L r F*

Possible Cause:

- Current greater than 500% of the motor FLA setting is detected for more than 200 ms during steady state operation.

Corrective Action:

- Check motor for locked shaft. Remove obstruction prior to restarting.

---

**Motor Underload Fault**

Fault Code: *ULLF*

Only applicable if ULL is programmed. ULL is factory pre-set to NO.

Possible Cause:

- Load level below the set ULL level.
- Damage to drive train (broken belts, shafts, etc.).
- Pump running dry or with no flow.

Corrective Action:

- Check the application for changes that may cause performance outside acceptable limits
  - Change in process, loading, or operation
  - Mechanical system inspection
  - Incident in pump hydraulic circuit

**Max Start Time Exceeded**

Fault Code: *5tLF*

Only applicable if tLS is programmed. tLS is factory pre-set to NO.

Possible Cause:

- Start time exceeds tLS maximum start time setting.
- Change in process, loading or operation.

Corrective Action:

- Check the application for changes that may cause performance outside acceptable limits
  - Mechanism wear
  - Mechanical incident

**External Fault**

Fault Code: *ELEF*

Only applicable if LI is programmed to detect external fault LIE. LI is factory pre-set to NO.

Possible Cause:

- External fault detected and signaled to the logic input.

Corrective Action:

- Check external fault detection mechanism.

**Internal Serial Link Fault**

Fault Code: *5LF*

Possible Cause:

- Bad connection of the keypad or serial link option module.

Corrective Action:

- Check option module connection
- Replace option module

**Overcurrent Fault**

Fault Code: *O c F*

Possible Cause:

- High impedance short circuit at the output of the controller
- Internal short circuit
- Improper sequence of shorting contactor

Corrective Action:

- Remove power from controller and check for:
  - Damage to power cables and/or motor insulation
  - Damage to thyristors
  - Damage to shorting contactor/contactor stuck in closed position

**Internal Failure Fault**

Fault Code: *I n F*

Possible Cause:

- Bad internal connection
- Rating not recognized

Corrective Action:

- Remove power from controller and check the internal connections.

**Phase Inversion Fault**

Fault Code: *P i F*

Only applicable if Phr is activated. Phr is factory pre-set to NO.

Possible Cause:

- Phase rotation of the mains does not match the Phr selection.

Corrective Action:

- Remove power from the motor and switch two phases of the mains supply.



**CHAPTER 6—SERVICING  
THE CONTROLLER**

INTRODUCTION .....62  
PERSONNEL PROTECTION PRECAUTIONS .....62  
LIST OF TOOLS AND INSTRUMENTS .....63  
STANDARDS .....63  
PARTS REPLACEMENT .....64  
CONTROL MODULE REPLACEMENT .....65  
POWER SECTION REPAIR .....66  
    ATS46D17 to C32 Controllers .....66  
    SCR Replacement .....67  
    Filter Card Replacement .....69  
    Thermal Switch and Fan Replacement .....69  
    Control Power Transformer (CPT) Replacement .....70  
POWER SECTION REPAIR .....71  
    ATS46C41N to M12 Controllers .....71  
    SCR Power Pole Assembly .....71  
    Firing Interface Board Replacement .....72  
    Current Measurement Board Replacement .....74  
    Thermal Switch Replacement .....75  
    Fan Replacement .....75  
    Control Power Transformer Replacement .....75

## INTRODUCTION

For the protection of personnel and equipment, a qualified maintenance person must perform the procedures detailed in this manual. The maintenance person should:

- Read, interpret, and follow instructions and precautions in this manual and the other manuals referenced.
- Use the tools listed on page 65 of this manual in a safe and technically correct manner.
- Perform troubleshooting and parts replacement procedures while following the safety procedures recommended in ANSI/NFPA 70E.
- Be trained on the operation and fundamentals of AC controllers and systems and be familiar with the associated hazards.

Review the sections below for personnel and equipment protection precautions before performing parts replacement procedures.

### DANGER

#### HAZARDOUS VOLTAGE

Read and understand this section before maintaining or servicing the ALTISTART 46 controller. Only qualified personnel should install, adjust, service, and maintain these controllers.

- Confirm that controller has been correctly selected, installed, and applied before performing any service or maintenance.
- Verify that all controller overcurrent protective devices, conductors, enclosures, and other circuit elements have been correctly selected for application and that controller is properly grounded in accordance with equipment instruction bulletin recommendations and applicable code requirements.
- Many parts in this controller, including printed circuit boards, operate at line voltage. DO NOT TOUCH. Use personal protective equipment and follow precautions and measurement procedures referenced in this bulletin when making any measurements on energized equipment. Use instruments and insulated tools approved for job.
- Install all covers before applying power or starting and stopping controller.
- Observe and follow all applicable lock-out and tag-out procedures for specific installation.

**Electrical shock will result in death or serious injury.**

## PERSONNEL PROTECTION PRECAUTIONS

ATS46 controllers contain components that can be potentially hazardous to maintenance personnel. Semiconductor devices can exhibit hazardous leakage currents in the “off” state. Personnel performing parts replacement should be thoroughly familiar with ANSI/NFPA 70E. Follow these safety measures:

1. Verify that the equipment has been installed and applied in a manner that is consistent with the information in the equipment instruction manual, applicable code requirements, and regulations.
2. Coordinate all parts replacement procedures with the operations manager of the facility.
3. Ensure that the controlled equipment is disconnected from the controller or that access to it is prohibited.
4. Read all precautions in this manual that relate to the procedure being followed.
5. Make sure you are familiar with the tools and instruments required for the specific procedures described in this chapter.
6. Ensure that you have proper body protection: clothing, eye protection, helmet, and other safety gear.
7. Ensure that electrical equipment surrounding the controller is either de-energized or isolated in such a way that maintenance personnel are not subject to electrical shock.

8. Ensure that all power sources feeding the controller are de-energized and locked/tagged out before opening the controller door or performing parts replacement procedures. Never assume the power is off. Always check for voltage with a properly rated voltage sensing device.
9. Inspect the controller bonding and ground system and ensure that the controller is properly grounded per the applicable codes and recommendations in this instruction bulletin.

ATS46 controllers use some specialized components to achieve rated performance during operation. Some of the components in the controller require special attention. For example, the SCRs require specific torque settings for proper operation. When replacing parts, follow the guidelines on page 2 and those listed throughout the book.

- Be sure to install thermal grease when mounting components which use the heatsink for dissipating heat (i.e., power semiconductor devices).
- Always torque semiconductor components using the method described in the applicable parts replacement procedure.
- If the controller is removed from its permanent mounting location while replacing parts, ensure that it is properly secured in an upright position before re-energizing.
- During maintenance, do not block, impede, or otherwise diminish cooling air flow over or through the controller.
- When installing a new control module, the controller may require programming if the factory default settings are not suitable for the specific application.
- Avoid touching exposed conductors and component leads with skin or clothing.

## LIST OF TOOLS AND INSTRUMENTS

The tools and instruments required to perform maintenance and replace components on the ATS46 controller are listed below:

- Set of magnetized flat blade screw drivers
- Set of magnetized phillips screw drivers
- Set of Torx® screw drivers
- 1/4" drive metric socket set, 5.5 to 14 mm
- One 2' (1/4" drive) socket extension
- One 2' (1/4" drive) socket extension
- Metric hex key set, 2 to 14 mm
- Regular hex key set, 1/4" to 9/16"
- Metric ball-end hex key set, 2 to 14 mm
- Torque wrench, 4.4 to 352 lb-in (0.5 to 40 N•m)
- Metric hex key sockets for torque wrench
- Metric drive sockets for torque wrench
- Thermal grease (Alcoa #2EJC or equivalent)
- Set of open/box end wrenches, 5.5 to 19 mm
- Multimeter, 0-1000 V (Fluke 87 or equivalent)
- Clamp-On Current Probe, 0-600 A (Fluke 80i-600A or equivalent)
- Connector Extractor

## STANDARDS

This manual references the latest revision of the following standards:

- ANSI/NFPA 70B, Electrical Equipment Maintenance
- ANSI/NFPA 70E, Electrical Safety Requirements for Employee Workplaces
- NEMA ICS 1.1, Safety Guidelines for the Application, Installation, and Maintenance of Solid State Control
- NEMA ICS 1.3, Preventive Maintenance of Industrial Control and Systems Equipment
- NEMA ICS 2 - Annex A, Maintenance of Motor Controllers After a Fault Condition
- OSHA 29 CFR Part 1910, Electrical Safety-Related Work Practices

**PARTS REPLACEMENT**

This section contains spare part information and parts replacement procedures for ATS46 controllers.

**Table 19: ATS46 Replacement Parts**

Replacement Part Description	Model	Catalog No.	
Control Module	All models	VX4-G461	
Control Terminal Strips	All models	VZ3N007	
Keypad	All models	VW3G46101U	
Thyristor Modules (2 SCR modules)	D17	VZ3TM2026M16	
	D22-D32	VZ3TM2055M16	
	D38	VZ3TM2090M16	
	D47-D88	VZ3TM2130M16	
	C11	VZ3TM2160M1601	
	C14-C25	VZ3TM2250M16	
(1 SCR module)	C32	VZ3TM1400M16	
(2 SCR modules w/o firing board)	C41-C66	VZ3TP2900M16	
	C79, M10-M12	VZ3TP2M12M16	
Firing Board	C41-M12	SF1LG220	
	D17	VX4G46101	
	D22	VX4G46102	
	D32	VX4G46103	
	D38	VX4G46104	
	D47	VX4G46105	
	D62	VX4G46106	
	D75	VX4G46107	
	D88	VX4G46108	
	C11	VX4G46109	
	C14	VX4G46110	
	Current Measurement Boards	C17	VX4G46111
		C21	VX4G46112
		C25	VX4G46113
		C32	VX4G46114
		C41	VX4G46115
		C48	VX4G46116
C59		VX4G46117	
C66		VX4G46118	
C79		VX4G46119	
M10		VX4G46120	
M12	VX4G46121		
Control Transformers	D17-062	VY1G461401	
	D75-C14	VY1G461402	
	C17-C32	VY1G461403	
	C41-M12	VY1KG461404	
Filter Card	D17-D38	VX4G46161	
	D47-C14	VX4G46163	
	C17-M12	VX4G46162	
Cooling Fan	D75-C14	SZ1XH07	
	C17-M12	VZ3V001	
Fan Cover	D75-C14	VY1G23101	
Thermal Switches	Heatsink (90 °C)	D75-C14	SY3AT0007
	Heatsink (105 °C)	C17-M12	SY3AT0011
	Cooling fan (50 °C)	D75-M12	VZ1GF01



## CAUTION

### EQUIPMENT DAMAGE

- ALTISTART 46 controllers use metric fasteners.
- Do not substitute SAE or alternate fasteners.

Failure to follow this instruction can result in equipment damage.

ATS46 controllers use metric fasteners and require the use of metric driver tools. Do not substitute SAE or any alternate fastener. Substitution may result in damage to threaded inserts, breakage of components and subassemblies, overheated electrical connections due to improper torque levels, and general structural failure.

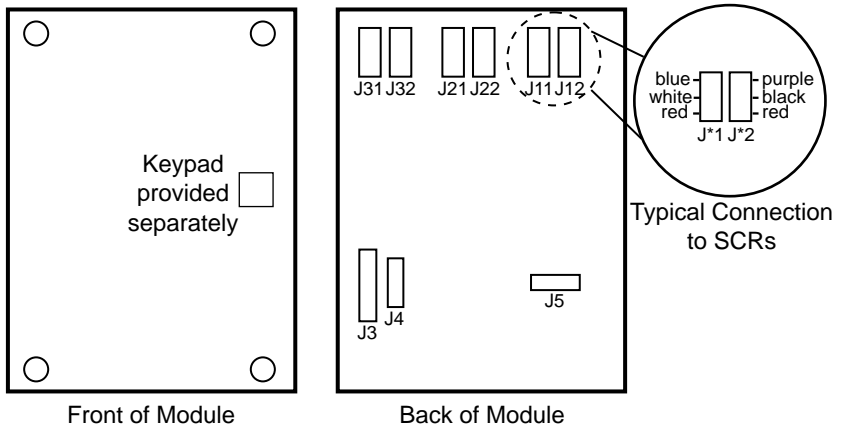
**All procedures in this section must be performed with power removed from the controller.**

## CONTROL MODULE REPLACEMENT

To gain access to the power section or for replacement on all ATS46 models, remove the control module.

*To remove the control module, follow these steps:*

1. Using a flat blade or Torx screw driver, remove the four screws from the front of the control module.
2. Using a connector extractor, disconnect the nine electrical connectors from the back of the module. While the connectors and module are labeled, note the label and location of each connector. Figure 45 shows a diagram of the module and its connector labels.



**Figure 45: Replacing the Control Module**

*To replace the control module, follow these steps:*

1. Install the electrical connections. Push all connectors so that they are firmly in place.
2. Mount the control module to the power section. Carefully secure all wires in the controller to prevent damage to the wire or loosening of the connections.
3. Retighten the four holding screws.

### NOTES:

*When the control module is damaged, the entire module must be replaced. Any attempt to access, repair, or inspect the control module's circuit boards voids the product warranty.*

*When replacing the control module, note that the replacement control module does not include the operator interface (keypad or communications module). The user must purchase a replacement operator interface separately.*

## POWER SECTION REPAIR ATS46D17 TO C32 CONTROLLERS

The control module must be removed to repair the components in the power section. The ATS 46 product line consists of five frame sizes which share common power section design. The replacement process for the power components is similar for units within a frame size. For units rated 17 through 320 amps, remove the control module and protective housing to access the power components directly.

These items are replaceable in the power section of the 17 through 320 A models (D17 to C32):

- SCRs
- Current measurement board
- Filter card
- Control power transformer
- Fan and thermal switches (on models rated 72 A and above)

Figures 46, 47, and 48 show available replacement parts. Table 19 on page 66 lists catalog numbers.

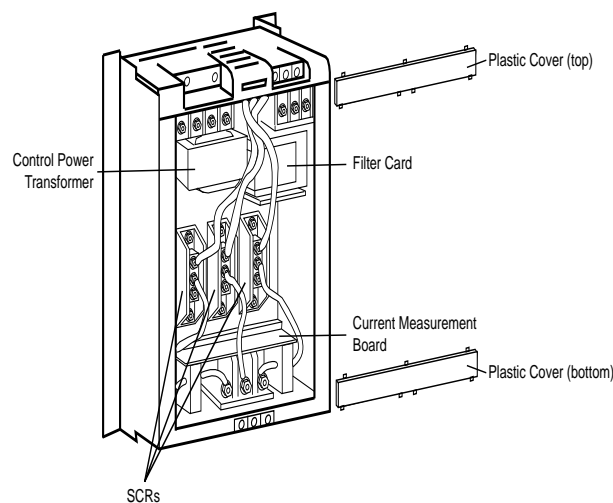


Figure 46: ATS46D17, D22, D32, and D38 Controllers

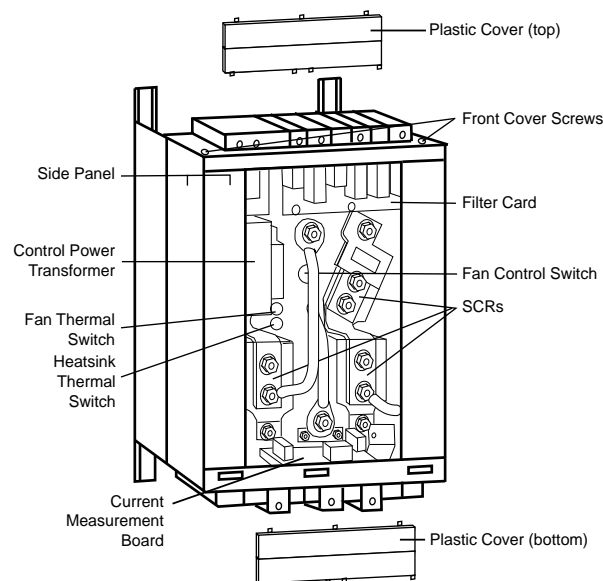
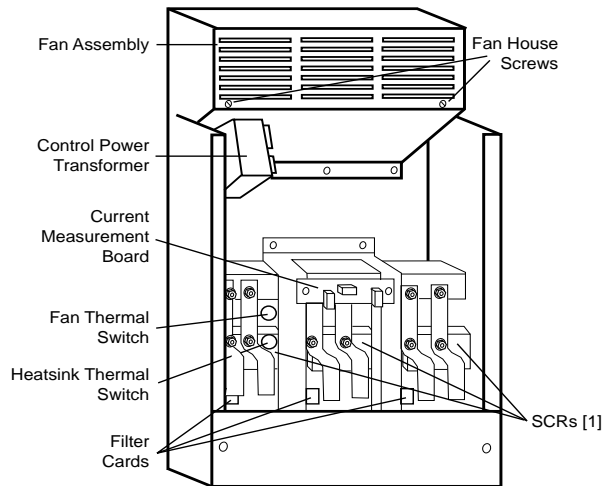


Figure 47: ATS46D47, D62, D75, D88, C11, and C14 Controllers



[1] Two per phase for ATS46C32. One per phase for ATS46C17 to C25.

**Figure 48: ATS46C17, C21, C25, and C32 Controllers**

### SCR Replacement

When an SCR fails, the ATS46 controller will not attempt to start the motor. Upon a start command, a device with a failed SCR immediately shows a phase fault or internal fault code.

**⚠ DANGER**

**HAZARDOUS VOLTAGE**

Before checking thyristors:

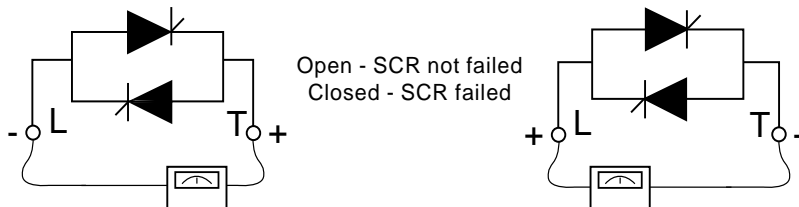
- Disconnect all power.
- Place a "DO NOT TURN ON" label on the controller disconnect.
- Lock disconnect in open position.

**Electrical shock will result in death or serious injury.**

To verify the damaged pole and determine how many poles should be replaced, perform the following tests. For D17 through C32 controllers, the SCR modules can be directly accessed.

*NOTE: The ATS46C32N controllers use two SCRs per phase. All other models use a dual pack SCR that requires one module per phase.*

1. With the equipment switched off, isolate the starter by disconnecting the power terminals.
2. Remove line power from controller. Using a continuity meter, check the thyristors in pairs. Figure 49 illustrates this process, phase by phase, between terminals 1L1-2T1, 3L2-4T2, 5L3-6T3. If continuity is indicated, at least one of the thyristors is short-circuited.



**Figure 49: Checking Thyristors**

To remove the SCR module, follow these steps:

1. Disconnect all electrical connections to the SCR module. Note the color and connection of each lead. Remove only one SCR module at a time so that the other modules may be used as a reference when replacing the SCR module.
2. Remove the power connections:
  - For D17 through C14 controllers: Use a hex key to remove the power straps which connect the SCRs to the line and load terminals.
  - For C17 through C32 controllers, first remove the filter card (see page 10). Then remove the bus bar connections using a 10 mm socket wrench (two bolts per phase).
3. Using an Allen wrench, remove the four screws at the base of the SCR module which hold the SCR to the heatsink.

To replace the SCR module, follow these steps:

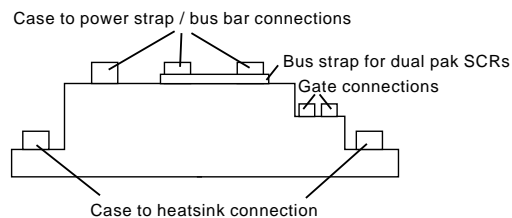
1. Apply a thin coat of thermal grease (e.g., Alcoa #2EJC or equivalent) between the heatsink and SCR for better heat transfer.

*NOTE: Do not allow grease to go into the threaded hole.*

2. Install the new SCR module, applying the proper torque to the screws holding the SCR to the heatsink and to the bolts connecting the power straps or bus bar to the SCR. Table 20 lists the proper tightening torque for the SCR connections.
3. Reconnect electrical leads to the SCR module in their original positions.

**Table 20: Tightening Torques**

ATS46-	SCR Part Number	Tightening Torque lb-in (N•m)	
		Case to Heatsink	Case to Bus Bar
D17N	VZ3TM2026M16	57.5 (6.5)	22 (2.5)
D22 - D32N	VZ3TM2055M16	57.5 (6.5)	22 (2.5)
D38N	VZ3TM2090M16	57.5 (6.5)	22 (2.5)
D47 - D88N	VZ3TM2130M16	57.5 (6.5)	40 (4.5)
C11N	VZ3TM2160M1601	57.5 (6.5)	57.5 (6.5)
C14 - C25N	VZ3TM2250M16	57.5 (6.5)	75 (8.5)
C32N	VZ3TM1400M16	57.5 (6.5)	75 (8.5)



**Figure 50: SCR Connections**

When replacing SCRs damaged from exposure to excessive current or voltage (e.g., short circuit or lightning strike), it is good practice to replace the current measurement board and filter card for the replaced poles.

## Filter Card Replacement

For D17 through C14 controllers, there is one filter card per unit mounted below the L1/L2/L3 connections. For C17 through C32 controllers, there are three filter cards—one mounted to the bus bar on each phase.

*To replace the filter card on D47 through C14 controllers, follow these steps:*

1. Disconnect electrical connections from the board. Note the position and color of each wire for reassembly.
2. Disconnect power straps to SCRs as needed to access filter card.
3. Using a flat blade screwdriver, remove the filter card mounting screws.
  - Removing the bus wiring may facilitate the removal of the filter card.
  - To access the filter card (in D47 through C14 controllers only), follow these steps:
    1. Take out the top two front cover screws. See Figure 47 on page 68.
    2. Take out the four screws from the bottom cover of the controller.
    3. Disconnect T1, T2, and T3 from SCR.
    4. Pull the bottom plastic end cap out.
    5. Slide side panels down.
6. Remove the filter card.
7. Use a magnetic screwdriver to reinsert screws. To reinstall the filter card, reverse steps 1 to 5. Retighten the housing screws and power connections.

*To replace the filter card on C17 through C32 controllers, follow these steps:*

1. Remove electrical connections for the card to be replaced.
2. Using a Torx screwdriver, remove the mounting screw.
3. Remove the filter card.
4. To reinstall a new filter card, reverse steps 1 through 3.

*To remove the current measurement board:*

1. For D47 through C32 controllers, disconnect jumpers J13, J14, and J15 from the current measurement board. See Figure 50 on page 70.
2. Using a Torx screwdriver, loosen and remove the holding screws on the current measurement board.
3. On D17 through D38 controllers, the current transformers are mounted directly on the current measurement board. To remove the board, the three bus wires from the SCRs have to be disconnected and pulled out from the current transformer.

*NOTE: To remove the bus wire from the current transformer, it may be necessary to remove the heat shrink from the terminal of the bus wire. Replace heat shrink upon re-installation.*

4. Remove measurement board from power section; note connections for reassembly.

## Thermal Switch and Fan Replacement

On ATS46D75 through C32N controllers, there are two thermal switches. One controls the operation of the cooling fan, and the other is an alarm for controller thermal protection. The output of the heatsink thermal switch is fed to the current measurement board. The output of the fan control is in series with the fan and control power transformer.

The cooling fans cycle on when the temperature of the heatsink exceeds 50 °C. If the cooling fan does not turn on and the temperature exceeds 50 °C, the thermal switch, the fan, or both may need to be replaced. The fans operate on 230 VAC single phase power. Use an external power supply, if desired, to test fan operation.

*To replace a thermal switch, follow these steps:*

1. Disconnect the two electrical connections from the output of the switch.
2. Using a Torx or flat blade screwdriver, remove the two holding screws. It may be necessary to remove some of the SCR power connections to access the thermal switch.
3. Replace the thermal switch with the appropriate rated switch. The fan thermal switch should be rated for 50 °C, whereas the heatsink switch is rated for 95 °C or 105 °C, depending on the controller size.

To replace the fan on D75 through C14 controllers, follow these steps:

1. Turn the unit with the heatsink facing up (i.e., access the fan from the back of the unit).
2. Remove the two electrical connections.
3. Remove the two holding screws.
4. To install the replacement fan, reverse steps 1 through 3.

To replace the fan on C17 through C32 controllers, follow these steps:

1. Remove the fan cover by removing the two cover screws.
2. Remove the six screws from the fan mounting plate.
3. Disconnect the fan power supply wires from the control power transformer (**White**) and from the thermal switch (**Red**). See Figure 51.
4. Remove the fan assembly.
5. To reinstall the replacement fan, reverse steps 1 through 4. Use caution when installing the fan to prevent damage to the wires.

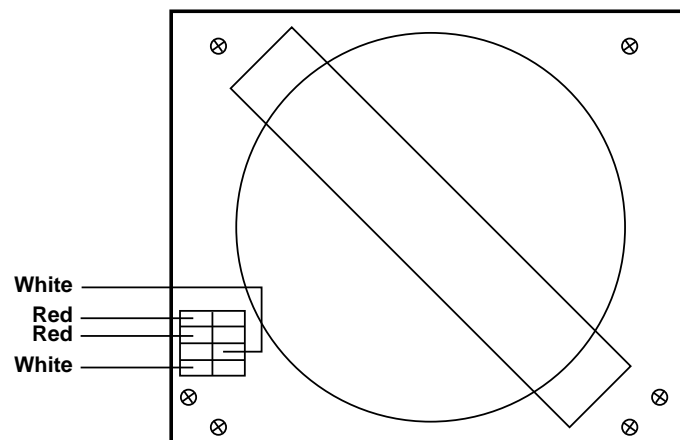


Figure 51: Fan Mounting Plate

### Control Power Transformer (CPT) Replacement

The control power transformer (CPT) provides the power to the control module and fan (if supplied). To replace the CPT, the user must have access to the fan connections. Refer to "Thermal Switch and Fan Replacement" on page 71 to service the fan assembly.

To replace the CPT, follow these steps:

1. Disconnect the four colored transformer supply wires from the terminal block beneath the control power connections. See Figure 57 on page 76.
2. For D72 through C32 controllers, disconnect the two wires that supply the fan power. For C17 through C32 controllers, pull the fan power wires through the fan and controller housing one at a time.
3. Remove the four transformer mounting screws attaching the transformer to the power section base.
4. Remove the CPT.
5. To install a replacement CPT, reverse steps 1 through 4. See Figure 57: Note the proper connections.

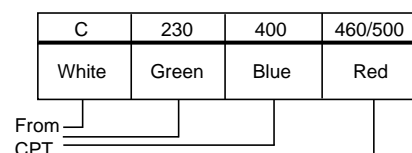


Figure 52: Control Power Transformer Wiring

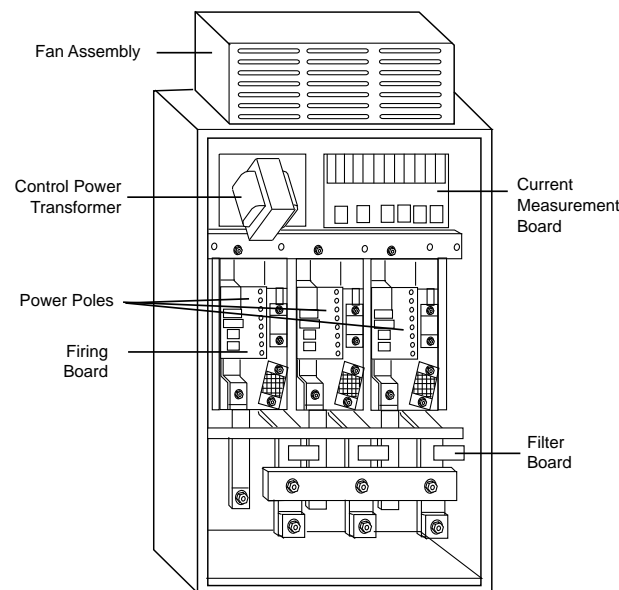
## POWER SECTION REPAIR ATS46C41N TO M12 CONTROLLERS

Some replacement parts on models ATS46C41 to M12N can only be accessed after removing other items in the power section. Make a record of the wire connections and the order and location of all components before removing them from the power section.

The following list contains replaceable items in the power section of the 410 through 1200 A models:

- Control module / Keypad
- SCR power pole assemblies
- Firing interface board
- Current measurement board
- Filter card
- Control power transformer
- Fan and thermal switches

Refer to Figure 53 to identify the available replacement parts. Table 19 on page 66 lists catalog numbers for each item. The instructions for replacing the control module, control power transformer, thermal switches, and fan are the same as for the ATS46C17 through C32N controllers described on pages 66 through 70.



**Figure 53: ATS46C41, C48, C59, C66, C79, M10, M12**

### SCR Power Pole Assembly

The SCR power pole assembly consists of the power pole, the firing interface board, and two thermal switches for ATS46C41 through M12N controllers. The power pole consists of two SCRs within a heatsink. The heatsink is tightened to provide balanced heat and current transfer within the assembly. The power pole, interface board, and thermal switches are available as individual parts. Pre-mounted thermal switches are provided with the replacement power pole.

*NOTE: SCRs are not available for individual replacement. Replacement of a single SCR through disassembly of the power pole will void the product warranty.*

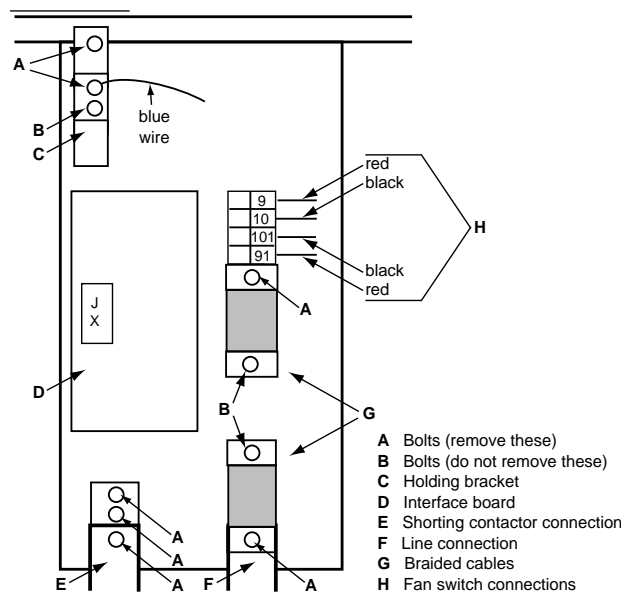
The ATS46C41 through M12 controllers use a firing interface board. Each SCR pole requires one interface board. Replace the board if there is visible damage to any of the components following an SCR failure. The replacement power pole assembly does not include an interface board. Reuse the original interface board (unless it is damaged) or order a replacement interface board.

Refer to page 68 for SCR testing information. The ATS46C79 through M12 controllers use two SCR power poles connected in parallel. If an SCR in either pole is shorted, replace both poles in the SCR assembly.

To replace the SCR package, interface board, or thermal switches, remove the entire power pole assembly. Removal allows easier access to the individual components. Note the location of each wire as you remove the assembly. The interconnections between the SCR pole and firing interface board are not labeled.

*To remove the power pole assembly from the controller chassis, follow these steps:*

1. Remove the control module as described on page 67.
2. Either rotate the control module mounting panel or remove it. Either action allows access to the SCR poles, current measurement board, and control power transformer.
3. Disconnect the jumper to the interface card from the current measurement board. The label designation, from J4 to J9, depends on which pole the jumper connects to.
4. To remove the SCR pole assembly, disconnect the wires and remove the bolts indicated in Figure 54. Use a 10 mm wrench to remove the bolts.
5. Cut wire ties from the power pole assembly to the insulating wall.
6. Pull the SCR pole assembly from the controller chassis using the handle on the mounting bracket (C in Figure 54) and the free end of the lower braided cable.



**Figure 54: SCR Power Pole Assembly**

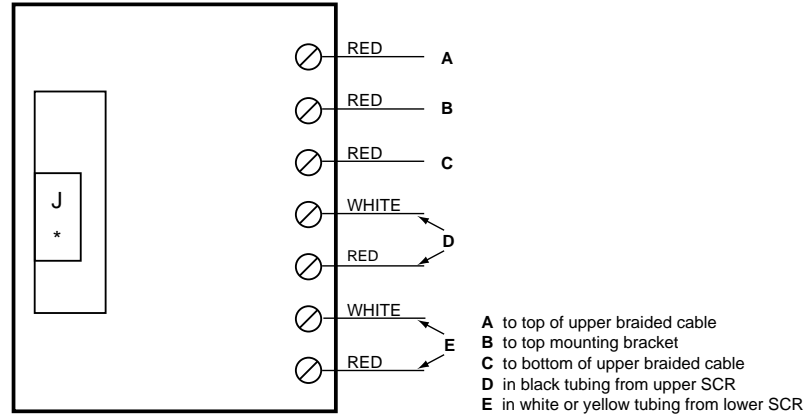
After removing the power pole assembly from the chassis, replace the SCR pole, interface board, or thermal switches.

### Firing Interface Board Replacement

*To replace the firing interface board, follow these steps:*

1. Label the wires connected to the interface board for easier identification when reassembling. Using a flat-head screwdriver, remove the seven screws holding red and white wires.
2. While holding interface board to pole assembly, remove two mounting screws and bolt on mounting bracket.
3. Reassemble pole by following step 2, then 1. Tighten the mounting bolts to 40 lb-in (4.5 N•m). In order for the controller to operate properly, the SCR firing circuits must be properly connected. Use Figure 55 on page 75 to identify the location of each wire.

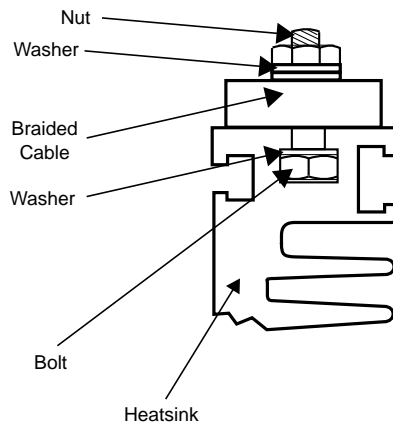




**Figure 55: Interface Board Connections**

To replace the power pole assembly on the controller chassis, follow these steps:

1. If replacing only the thermal switch or interface board, re-assemble the components to complete the power pole assembly. Complete this step before mounting the pole back in the controller chassis. Skip to step 3.
2. If replacing the SCR pole, remove the braided cables and standoffs. Use these in the new pole assembly. When replacing the braided cables, make sure cables are flush with the top side of the channel. Otherwise, proper conduction may not occur. Refer to Figure 56 for assembly of the cable to the channel.
3. Replace the red wire that is attached to the mounting bracket of the replacement pole. Re-tighten screw to maintain proper alignment of bracket.
4. Using the free end of the lower braided cable and the mounting bracket handle, replace the pole in the controller chassis.
5. Replace the removed wire from the pole assembly. Tighten the following to 80 lb-in (9 N•m): all 10 mm bolts holding the power pole assembly to the chassis; all connections to the bus bar.
6. Replace the jumper from the current measure board (see Figure 57 on page 76). Connect the four wires to the terminal block (see Figure 54 on page 74).
7. For C79 through M12 controllers: tighten to 40 N•m all bolts that connect the poles in parallel.

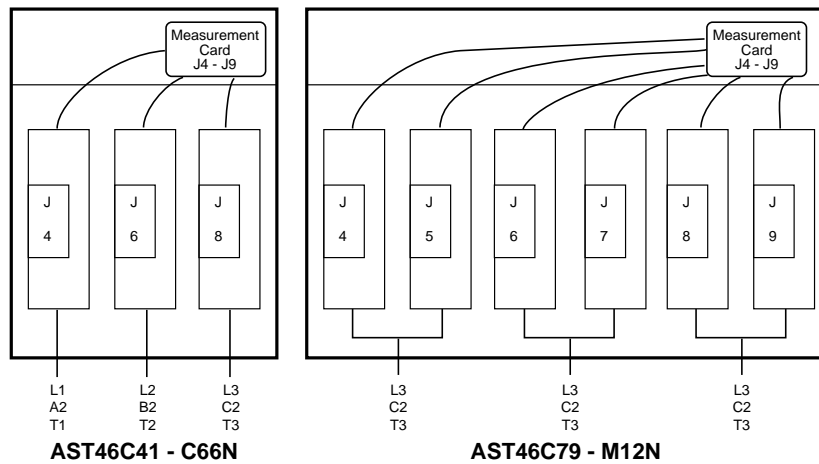


**Figure 56: Assembly of Braided Cable to Heatsink**

**Current Measurement Board Replacement**

The current measurement board, located behind the control mounting bracket on the angled part of the controller body, takes input from the current transformers; scales it; and provides the control module with motor current information for the control algorithms. For controllers with ratings of 410 A or higher, the current measurement board includes the gate drivers that higher rated SCRs require. If the current measurement board is damaged, acceleration or deceleration will not occur properly. To verify whether the current measurement board is working properly, compare the current display on the keypad to actual measured current.

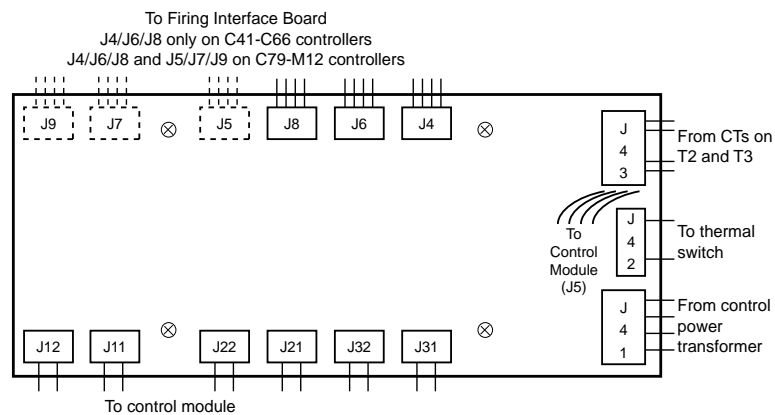
Typical causes of measurement board damage include exposure to a short circuit, excessive current flow, or improper shorting contactor sequencing. Replace the measurement board when replacing SCRs that are damaged by short circuit or lightning strike.



**Figure 57: Power Pole Configuration for C41 to M12 Controllers**

To remove the current measurement board, follow these steps:

1. Disconnect the plugs from the current measurement board. See Figure 58.
2. Using a Torx screwdriver, loosen and remove the holding screws from the current measurement board.
3. Carefully remove the measurement board from the power section. Note the location of the removed connections.



**Figure 58: Current Measurement Board**

To replace the current measurement board, follow these steps:

1. Mount the board to the controller. Tighten the holding screws.
2. Reconnect all jumpers to the measurement board.
3. If plugs were removed, reconnect plugs on the end of the wires opposite the control module and SCR poles.

*NOTE: The power section of the ATS46C79 through M12 controllers uses two power sections connected in parallel. The replacement instructions are the same for the C79 to M12 controllers except for pole connections. Figure 53 on page 73 shows pole connections for the C41 through M12N.*

### Thermal Switch Replacement

The thermal switches from each pole are connected in series for operation of the fan and indication of heatsink over temperature. When replacing the thermal switch, note the location of the existing switch connection to the terminal block. This connection, on the pole assembly, is critical to proper operation of the fan and thermal alarm.

On the ATS46C41 through M12 controllers, there are thermal switches for fan control and detection of the heatsink temperature on each power pole assembly. The SCR power poles must be removed to gain access to the thermal switches.

### Fan Replacement

Use the same fan replacement in the ATS46C41 through M12 controllers as for the ATS46C14 through C30 controllers. Refer to page 77 for fan replacement instructions. On C79 through M12 controllers, each fan operates independently, based on the left and right side temperature.

### Control Power Transformer Replacement

Control power transformer replacement for ATS46C41 through M12 controllers is the same as for ATS46C17 through C32 controllers. Refer to page 72 for CPT replacement instructions.

## CAUTION

### EQUIPMENT DAMAGE

- After completing any repair of the ALTISTART controller, ensure that all power connections are properly tightened and that the starter programming meets the application requirements.
- Do not substitute SAE or alternate fasteners.

**Failure to follow this instruction can result in injury or equipment damage.**

For additional assistance with replacing components or troubleshooting the ALTISTART controller, contact your local Square D Field Sales office, Square D Technical Services Department (800-634-2003), or the Square D Drives Product Support Group (919-217-6536).



Table 20: Controller-Motor Combinations

ATS46 Model	Rated Current	Standard Duty Applications Motor Power Rating			Heavy Duty Applications Motor Power Rating		
		208V	230V	460V	208V	230V	460V
	$I_{CL}$						
ATS46D17N	17	3	5	10	2	3	7.5
ATS46D22N	22	5	7.5	15	3	5	10
ATS46D32N	32	7.5	10	20	5	7.5	15
ATS46D38N	38	10	-	25	7.5	10	20
ATS46D47N	47	-	15	30	10	-	25
ATS46D62N	62	15	20	40	-	15	30
ATS46D75N	75	20	25	50	15	20	40
ATS46D88N	88	25	30	60	20	25	50
ATS46C11N	110	30	40	75	25	30	60
ATS46C14N	145	40	50	100	30	40	75
ATS46C17N	176	50	60	125	40	50	100
ATS46C21N	210	60	75	150	50	60	125
ATS46C25N	257	75	100	200	60	75	150
ATS46C32N	320	100	125	250	75	100	200
ATS46C41N	410	125	150	300	100	125	250
ATS46C48N	480	150	-	350	125	150	300
ATS46C59N	590	-	200	400	150	-	350
ATS46C66N	660	200	250	500	-	200	400
ATS46C79N	790	250	300	600	200	250	500
ATS46M10N	1000	350	400	800	250	300	600



**GROUPE SCHNEIDER**

■ Merlin Gerin ■ Square D ■ Telemecanique